

# **fantini** north **america**



**Model**

# **G03**

**SPARE PARTS CATALOG**



FANTINI NORTH AMERICA LLC  
15526 90th Street NE - Drayton, ND 58225  
P 1-800-454-3875  
fantini-na.com

**Serial Number:**

|  |  |  |  |  |
|--|--|--|--|--|
|  |  |  |  |  |
|--|--|--|--|--|



**This Handbook and its annexes may not be tampered with or modified, copied or given to third parties without FANTINI NORTH AMERICA'S authorization. We are sure you will be pleased with your purchase, and are always at your service for any explanations or assistance you may require. The handbook must be kept in a safe place throughout the working life of the machine, of which it forms an integral part. If the machine is sold on, ensure that the handbook and all its annexes (diagrams, layouts, foundation drawings etc) are also consigned. The information in this handbook does not replace the safety regulations and technical data for installation and operation applied directly to the machine, the safety norms in force in the country of installation, or the rules dictated by common sense. Bear in mind that this document cannot compensate for the shortcomings of operatives or maintenance staff who do not have the necessary technical skills or abilities.**













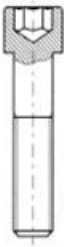













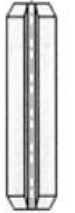



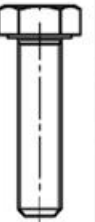











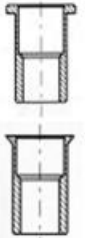

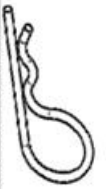











#### HOW TO USE THE FANTINI NORTH AMERICA SPARE PARTS CATALOG

-For the sake of simplicity the spare parts catalog contains only UNI identifications.  
*The section of quantity shows the amount of that spare part in the diagram*

| <b>Pos.</b>                      | <b>Number</b>          | <b>Description</b>        |
|----------------------------------|------------------------|---------------------------|
| <b>ID Number on Diagram Page</b> | <b>Spare Part Code</b> | <b>UNI Identification</b> |

# UNI - ISO

*International Organization for Standardization*

|   |   |   |  |   |
|---|---|---|--|---|
|  |  |  |                                     |  |
| UNI 5931 8.8<br>ISO 4762  | UNI 6592<br>ISO 7092  | UNI 7474 B<br>DIN 985   | UNI 5737 8.8<br>ISO 4014   | UNI 9200<br>ISO 7337  |
|  |  |  |                                     |  |
| UNI 5933 10.9<br>DIN 7991   | UNI 6593<br>ISO 7093  | UNI 7473 A<br>ISO 7040  | UNI 5737 10.9<br>ISO 4014  | UNI 5732<br>ISO 8677/4034   |
|  |  |  |                                     |  |
| UNI 5923 45H<br>ISO 4026  | UNI 6604<br>ISO R773  | UNI 1751<br>ISO 7040  | UNI 5738 8.8<br>ISO 8765   | UNI 6873<br>ISO 8752  |
|  |  |  |                                     |  |
| UNI 5927 45H<br>ISO 4027  | RDE UNI8842A<br>ISO 6798A   | UNI 7663A<br>ISO 71412A   | UNI 5739 8.8<br>ISO 4017   | UNI 5587<br>ISO 4033  |
|  |  |  |                                     |  |
| UNI 5925 45H<br>ISO 4028  | Est. UNI 7435<br>DIN 471  | UNI 7663B 45°<br>ISO 71412B   | UNI 5739 10.9<br>ISO 4017  | UNI 5588<br>ISO 4032  |
|    |    |    |                                       |    |
| UNI 8117<br>ISO 18480   | Int. UNI 7437<br>DIN 472  | UNI 7663C 90°°°<br>ISO 71412C   | UNI 5740<br>ISO 8676   | UNI 5589<br>ISO 4035  |
|    |    |    |  |    |
| CONTACT   | UNI9201   | DIN 6923  | "A" UNI 8833   | NIILOS 2207 JV  |
|    |    |    |                                       |    |
| 6307  | 30207   | 6206 2RS  | 30208  | NIILOS 6207 JV  |
|    |    |    |                                       |    |
| 6207  | 6205 2RS  | 6205 2RS  | 32207  | OR 4118   |
|    |    |    |                                       |    |
| 6208  | 6304 2RS  | PNA 2042  | 6004-2RS   | OR 3137   |
|    |    |    |                                       |    |
| 6209  | 2207 2RS  | 6307  | 61904 2RS  | 30209   |

# INDEX

## A

### Row Units

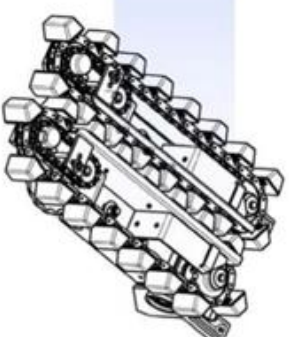

- A 01 Left Fork
- A 02 Right Fork
- A 03 Row Unit
- A 04 Gathering Chain With Rubber Teeth
- A 05 Row Unit Drive Connections

## B

### Bonnets



- B 01 Right Side Panels
- B 02 Left Side Panels
- B 03 Collecting Pans

## C

### Mesh

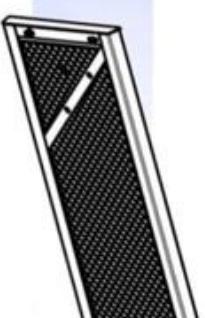

- C 01 8 Row Mesh
- C 02 12 Row Mesh

## D

### Transmission



- D 01 8 Row Side Transmission
- D 02 12 Row Side Transmission
- D 03 12 Row Rear Transmission
- D 04 Drive Shafts

## E

### Auger



- E 01 8 Row Auger
- E 02 12 Row Two Piece Auger
- E 03 12 Row Three Piece Auger

# A 01

## LEFT FORK

fantini north america

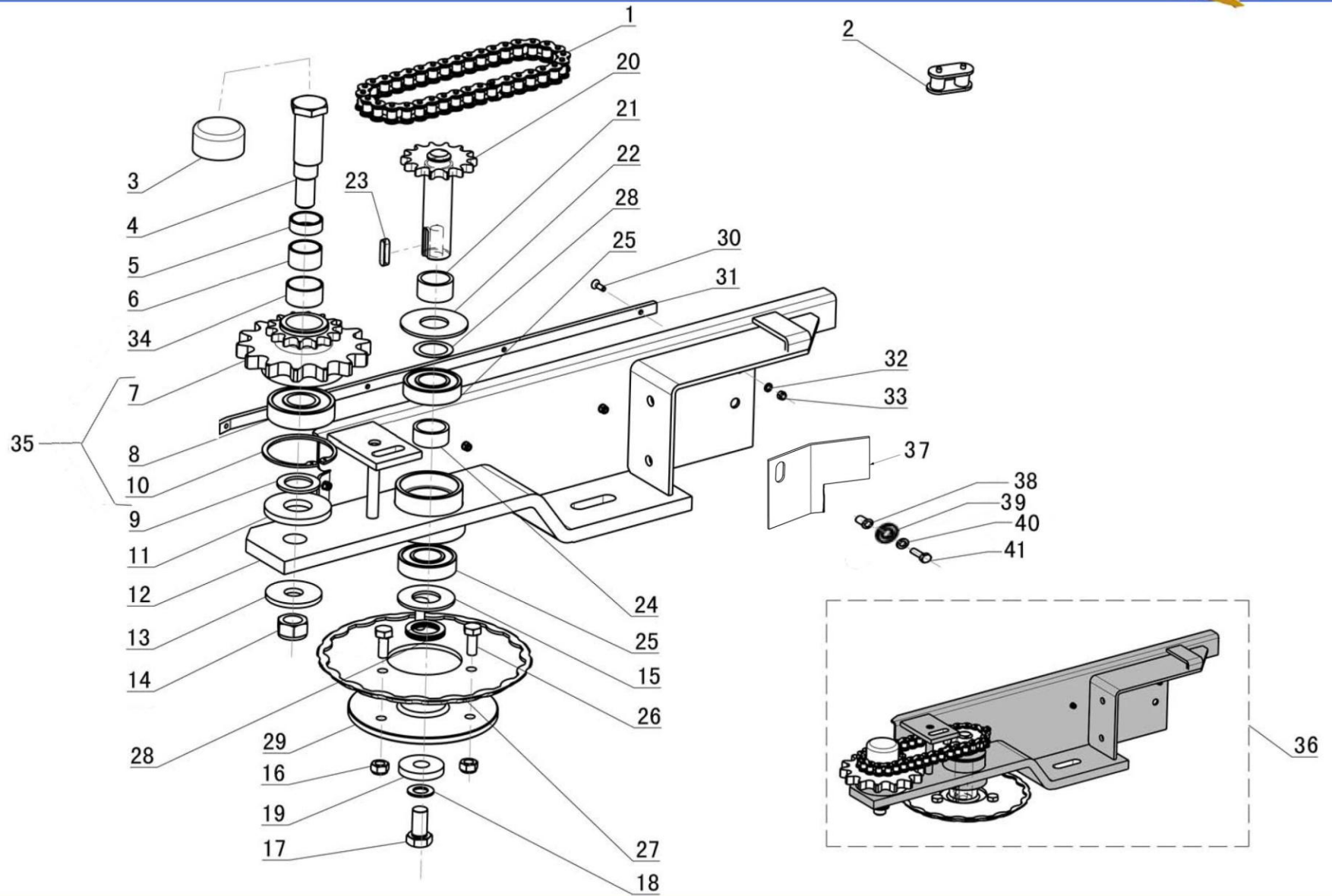

# Left Fork

| <u>Pos.</u> | <u>Number</u> | <u>Description</u>                | <u>Pos.</u> | <u>Number</u> | <u>Description</u>       |
|-------------|---------------|-----------------------------------|-------------|---------------|--------------------------|
| 1           | 03032         | Chain ASA 50 35 Links             | 22          | 06828         | Spacer 72X30.5-3         |
| 2           | 03122         | Connector Link ASA 50             | 23          | 00603         | Key Way 8X7X30 NI 6604   |
| 3           | 03374         | Cap                               | 24          | 03354         | Spacer 38X31-15.6        |
| 4           | 13868         | Eccentric Pin E36 D30X076 M20X036 | 25          | 01261         | Bearing 06206-2RS        |
| 5           | 03494         | Bushing 30 x 35 x 12.5            | 26          | 00375         | Bolt M10X25 UNI 5739     |
| 6           | 03495         | Bushing 30 x 35 x 20.5            | 27          | 20405         | Cutting Disc             |
| 7           | 03417         | Double Sprocket 1"1/8 Z014        | 28          | 01035         | Shim 42X30X0.5           |
| 8           | 01274         | Bearing 06306-2RS                 | 29          | 03376         | Mounting Plate           |
| 9           | 03351         | Spacer 46X30-3                    | 30          | 00524         | Bolt TS M05X16 UNI 5933  |
| 10          | 00583         | Snap Ring UNI 7473-75 INT 75      | 31          | 18756         | Chain Guide              |
| 11          | 03693         | Washer 30X71X8                    | 32          | 00919         | Lock Washer M5 UNI 8842  |
| 12          | 03386         | Left Row Unit Fork                | 33          | 00455         | Nut M5 UNI 5587          |
| 13          | 01068         | Washer 20X60X50                   | 34          | 03496         | Spacer 35X39X2OP10       |
| 14          | 04864         | Nut M20 UNI 7473                  | 35          | 07896         | Double Sprocket Assembly |
| 15          | 03371         | Spacer                            | 36          | 03284         | Complete Left Fork       |
| 16          | 04859         | Nut M10 UNI 7473                  | 37          | 16286         | Left Anti Seed Loss      |
| 17          | 00440         | Bolt M16X30 UNI 5739              | 38          | 10950         | Insert                   |
| 18          | 00917         | Lock Washer M16 UNI 8842          | 39          | 05127         | Washer M08               |
| 19          | 03327         | Washer 17X48X8                    | 40          | 00916         | Lock Washer M08 UNI 8842 |
| 20          | 03378         | Disc Shaft                        | 41          | 00383         | Bolt M8X20               |
| 21          | 03353         | Spacer 38X31-20                   |             |               |                          |

# A 02

## RIGHT FORK

fantini north america

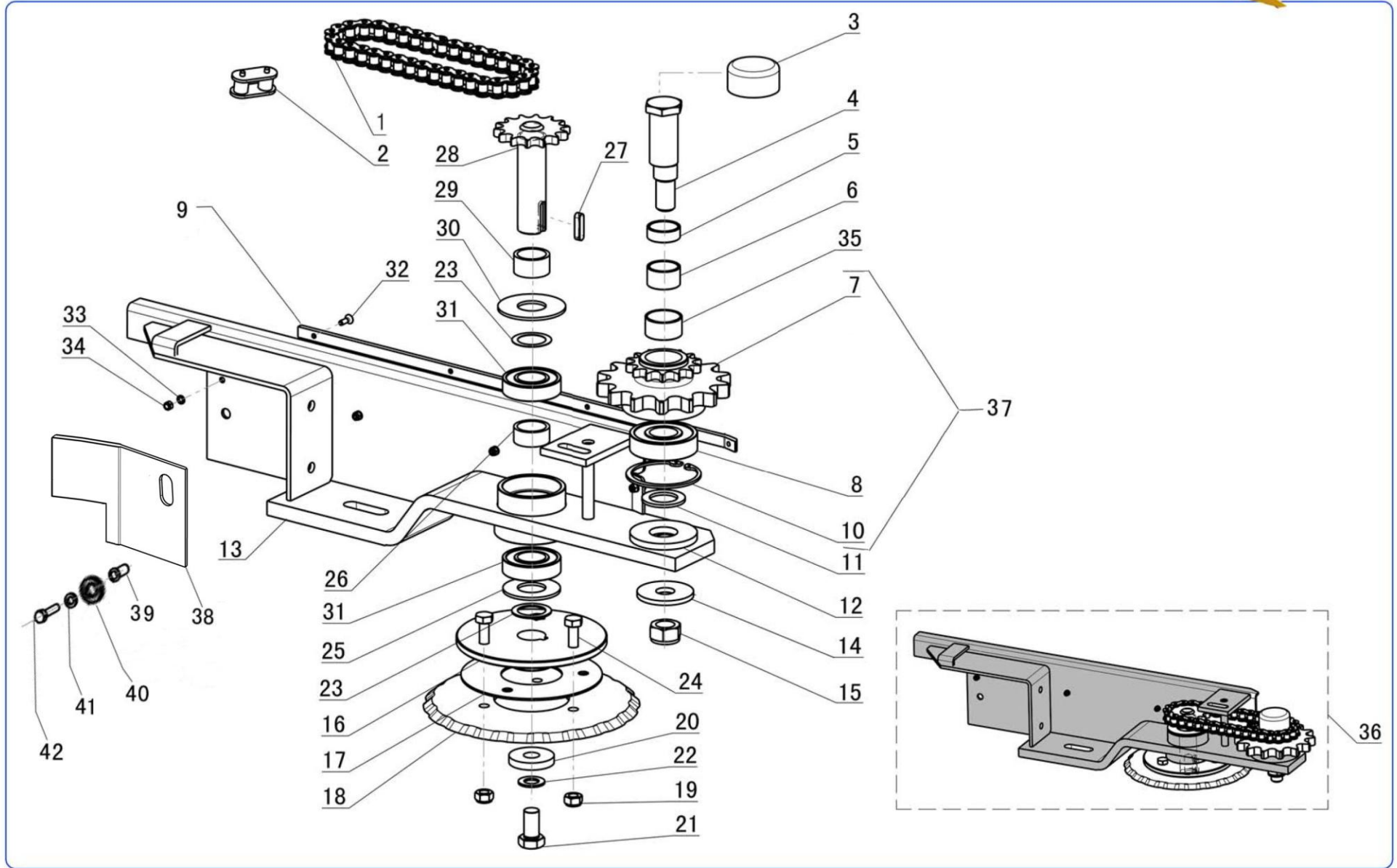



# Right Fork

| <u>Pos.</u> | <u>Number</u> | <u>Description</u>           | <u>Pos.</u> | <u>Number</u> | <u>Description</u>          |
|-------------|---------------|------------------------------|-------------|---------------|-----------------------------|
| 1           | 03032         | Chain ASA 50 35 Links        | 22          | 00917         | Lock Washer M16 UNI 8842    |
| 2           | 03122         | Chain Coupling ASA 50        | 23          | 01035         | Shim 42X30X0.5              |
| 3           | 03374         | Cap                          | 24          | 00375         | Bolt TE M10X25 UNI 5739     |
| 4           | 13868         | Eccentric Pin                | 25          | 03371         | Spacer                      |
| 5           | 03494         | Bushing 30 x 35 x 12.5       | 26          | 03354         | Spacer 38X31-16.5           |
| 6           | 03495         | Bushing 30 x 35 x 20.5       | 27          | 00603         | Key Way 8X7X30 UNI 6604-69B |
| 7           | 03417         | Double Sprocket 1"1/8 Z014   | 28          | 03378         | Disc shaft                  |
| 8           | 01274         | Bearing 06306-2RS            | 29          | 03353         | Spacer 38X31-20             |
| 9           | 18756         | Chain Guide                  | 30          | 06828         | Spacer 72X30.5X3            |
| 10          | 00583         | Snap Ring UNI 7473-75 INT 75 | 31          | 01261         | Bearing 06206-2RS           |
| 11          | 03351         | Spacer 46X30-3               | 32          | 00524         | Bolt TS M5X16 UNI 5939      |
| 12          | 03693         | Washer 71.4X30-8             | 33          | 00919         | Washer M5 UNI 8842          |
| 13          | 03385         | Right Row Unit Fork          | 34          | 00455         | Nut M5 UNI 5587             |
| 14          | 01068         | Washer 20X60X5               | 35          | 03496         | Spacer 35X39X20P10          |
| 15          | 04864         | Nut M20 UNI 7473             | 36          | 03283         | Complete Right Fork         |
| 16          | 03376         | Mounting Plate               | 37          | 07896         | Double Sprocket Assembly    |
| 17          | 17030         | Cutting Disk Spacer          | 38          | 16285         | Right Anti Seed Loss        |
| 18          | 20405         | Cutting Disc                 | 39          | 10950         | Insert                      |
| 19          | 04859         | Nut M10 UNI 7473             | 40          | 05127         | Washer M08                  |
| 20          | 03327         | Washer 17X48X8               | 41          | 00916         | Lock Washer M08 UNI 8842    |
| 21          | 00440         | Bolt M16X30 UNI 5739         | 42          | 00383         | Bolt M8X20                  |

# A 03 ROW UNIT

fantini north america

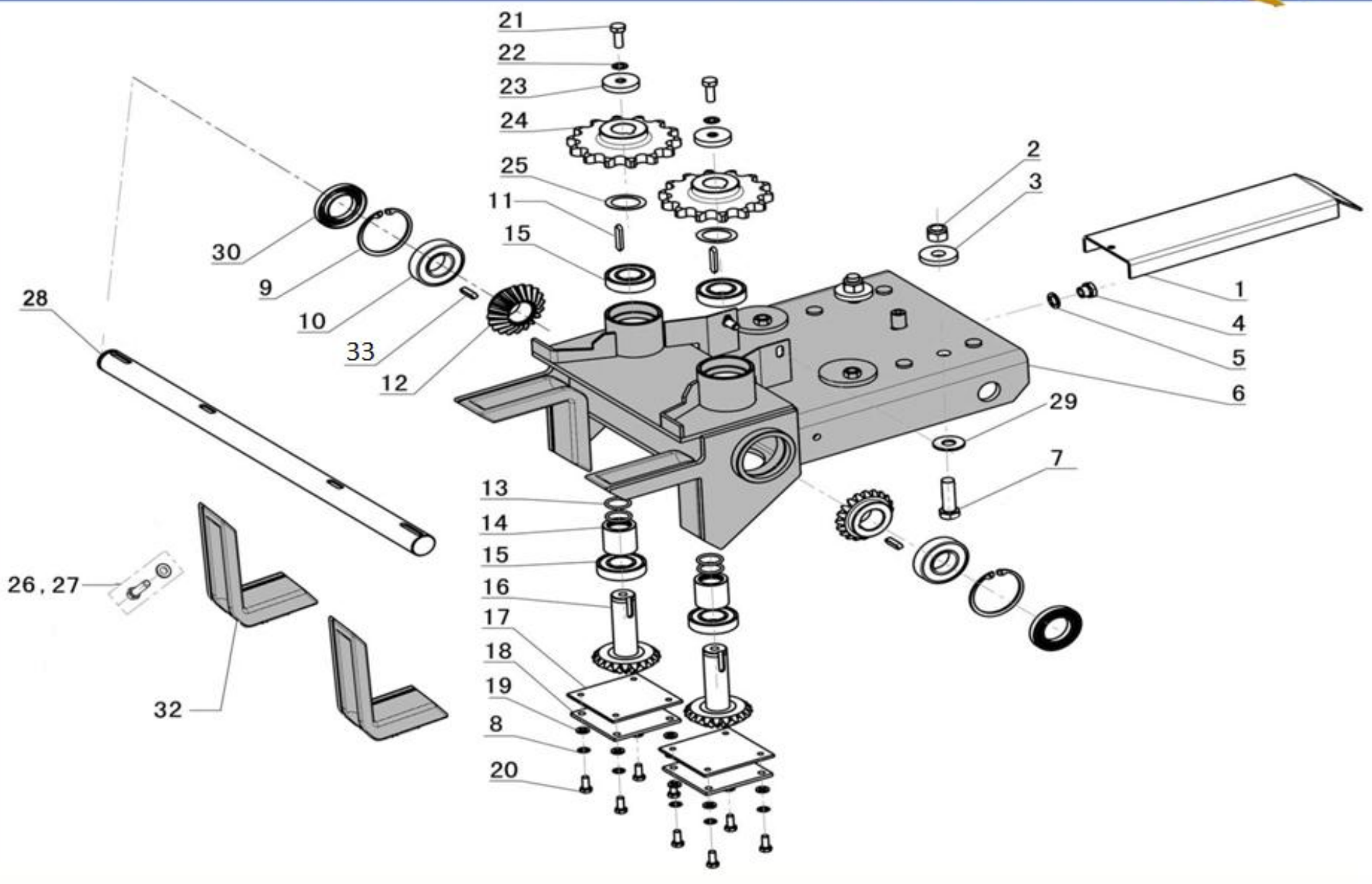

# Row Unit

| <u>Pos.</u> | <u>Number</u> | <u>Description</u>              | <u>Pos.</u> | <u>Number</u> | <u>Description</u>           |
|-------------|---------------|---------------------------------|-------------|---------------|------------------------------|
| 1           | 03324         | Transition Pan                  | 17          | 02516         | Square Gasket 100x04x100     |
| 2           | 04863         | Nut M16 UNI 7474 B              | 18          | 23187         | Cover 100X5 - 100            |
| 3           | 03327         | Washer 17.0 X 48.0 X 08.0       | 19          | 00946         | Washer M08 UNI 8842          |
| 4           | 03925         | 3/8 Plug                        | 20          | 00383         | Bolt M08X020 UNI 5739 08.8   |
| 5           | 12317         | Gasket 24 X 16 - 2              | 21          | 00384         | Bolt M10X030 UNI 5739 10.9   |
| 6           | 21675         | Row Unit Frame                  | 22          | 00918         | Lock Washer M10 UNI 6592     |
| 7           | 00441         | Bolt M16X055 UNI 5739           | 23          | 03319         | Washer 13.0X46.0X08.0        |
| 8           | 00916         | Lock Washer M08 UNI 6592        | 24          | 03392         | Sprocket 1" 1/8 Z014         |
| 9           | 00583         | Snap Ring Uni 7437 - 75 INT. 75 | 25          | 01035         | Spacer 42.0X30.0X0.5         |
| 10          | 01266         | Bearing 6207                    | 26          | 00450         | Bolt TE M12X040 UNI 5737 8.8 |
| 11          | 00603         | Key Way 08 X 07 X 030           | 27          | 00905         | Washer M12                   |
| 12          | 18144         | Gear M04 Z020 D.35              | 28          |               | See pg. A-05                 |
| 13          | 01289         | O-Ring 4118 29,75X3,53          | 29          | 00942         | Washer M16                   |
| 14          | 18729         | Spacer                          | 30          | 01335         | Seal 45X72X10                |
| 15          | 01261         | Bearing 6206-2RS                | 32          | 17396         | Row Unit Clamp               |
| 16          | 03400         | Ring gear with shank M04 Z020   | 33          | 18227         | Key way 08 X06X30            |

# A 04

## GATHERING CHAIN WITH RUBBER TEETH

**fantini** north america

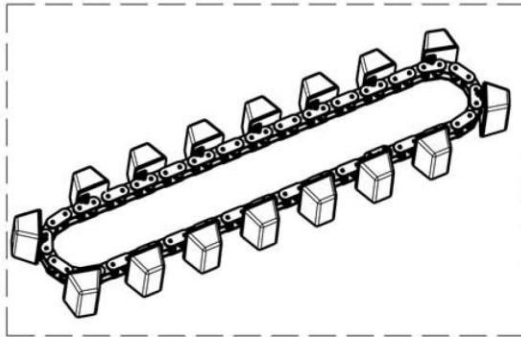

6

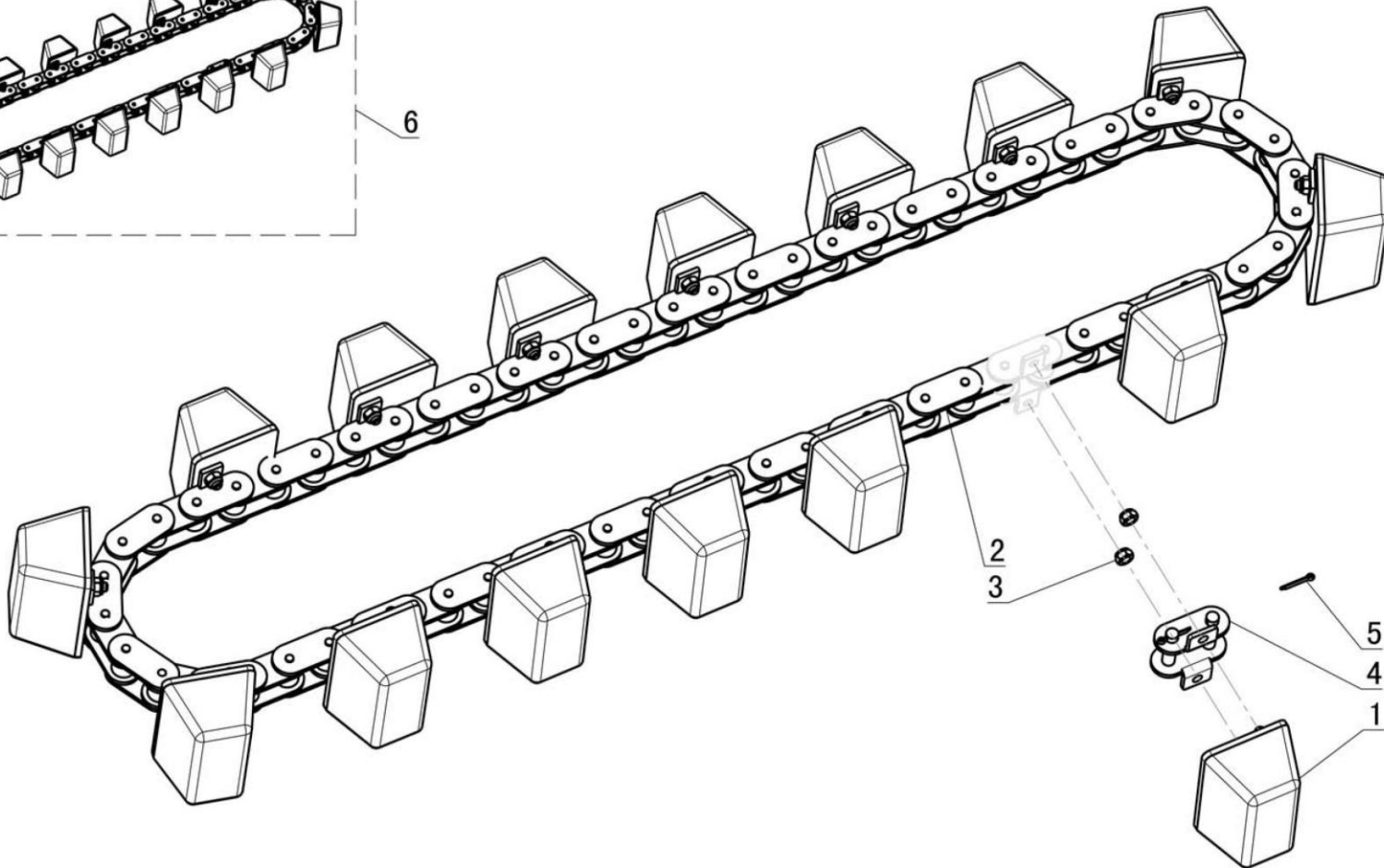

# Gathering Chain with Rubber Teeth

| <u>Pos.</u> | <u>Number</u> | <u>Description</u>          |
|-------------|---------------|-----------------------------|
| 1           | 18721         | Rubber Tooth                |
| 2           | 03743         | Chain CAE44151              |
| 3           | 04868         | Nut M6 UNI 7474             |
| 4           | 21457         | Chain Connectors            |
| 5           | 22417         | Cotter Pin 2.5X016 UNI 1336 |
| 6           | 19640         | Complete Gathering Chain    |

# A 05

## ROW UNIT DRIVE CONNECTIONS

fantini north america

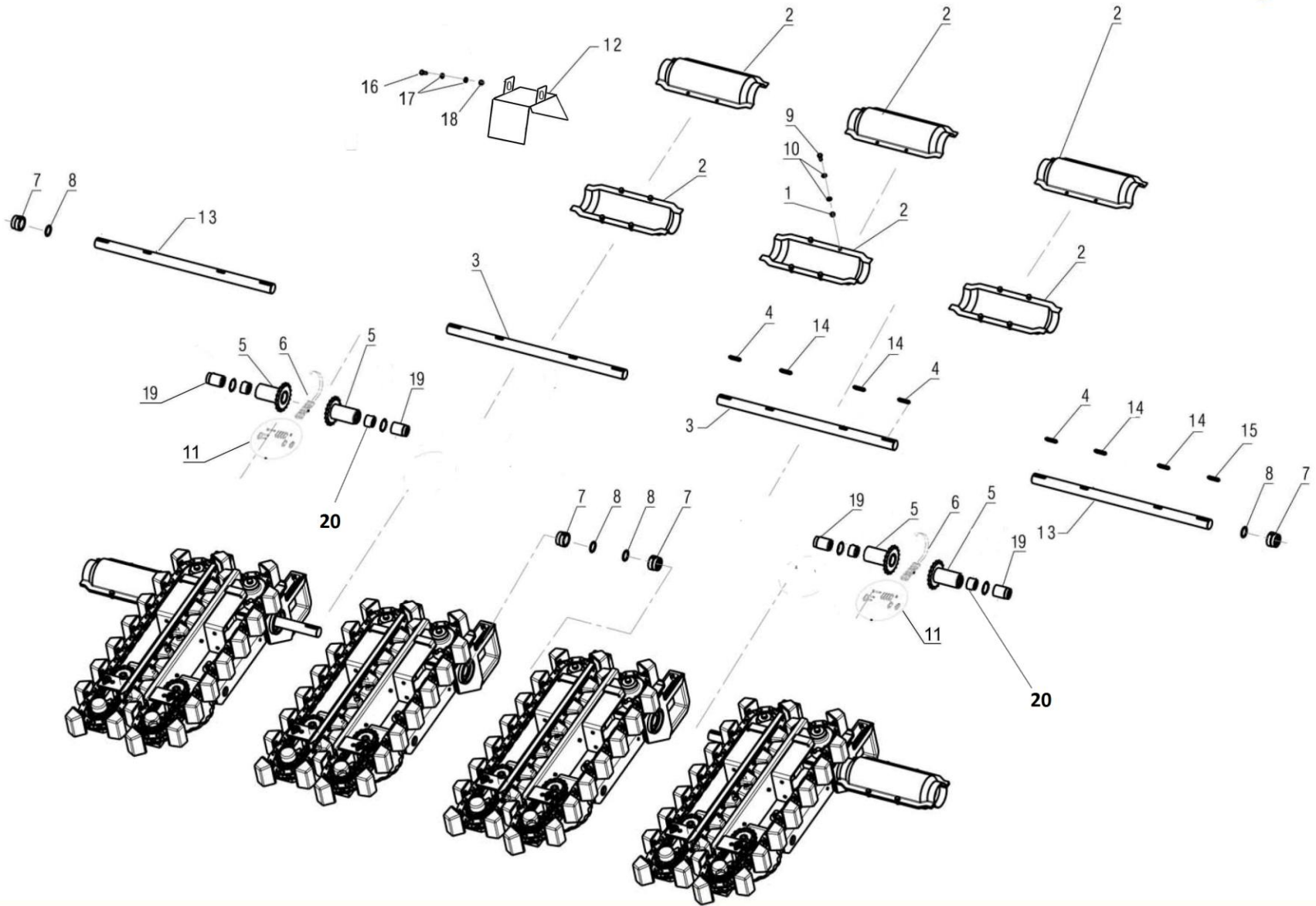

# Row Unit Drive Connections

| <u>Pos.</u> | <u>Number</u> | <u>Description</u>          | <u>Pos.</u> | <u>Number</u> | <u>Description</u>        |
|-------------|---------------|-----------------------------|-------------|---------------|---------------------------|
| 1           | 04858         | Nut M8 AUT UNI 7473         | 11          | 03121         | Connector Link            |
| 2           | 21946         | Shield                      | 12          | 27468         | Connection Shield 22in.   |
| 3           | 18969         | Center Shaft 30in. L=698    | 12          | 25541         | Connection Shield 20in.   |
| 3           | 20487         | Center Shaft 22in. L=558    | 13          | 22311         | Lateral Shaft 30in. L=777 |
| 3           | 18993         | Center Shaft 20in. L=498    | 13          | 18983         | Lateral Shaft 30in. L=731 |
| 4           | 00605         | Key Way 08X07X45            | 13          | 23340         | Lateral Shaft 22in. L=707 |
| 5           | 02481         | Coupling Sprocket 30in      | 13          | 24620         | Lateral Shaft 20in. L=677 |
| 5           | 22952         | Coupling Sprocket 20 & 22in | 14          | 18227         | Key Way 8X7X30            |
| 6           | 17402         | Chain ASA 50-2              | 15          | 00607         | Key Way 10X8X55           |
| 7           | 23355         | Collar                      | 16          | 00384         | Bolt M10X30               |
| 8           | 01321         | O-Ring 4137 34.52X3.53      | 17          | 20533         | Washer M10                |
| 9           | 00383         | Bolt M8X20 UNI 5739         | 18          | 04859         | Nut M10                   |
| 10          | 00946         | Washer M8 UNI 6592          | 19          | 23356         | Collar                    |
|             |               |                             | 20          | 23308         | Spacer                    |

# B 01

## RIGHT SIDE PANELS

fantini north america

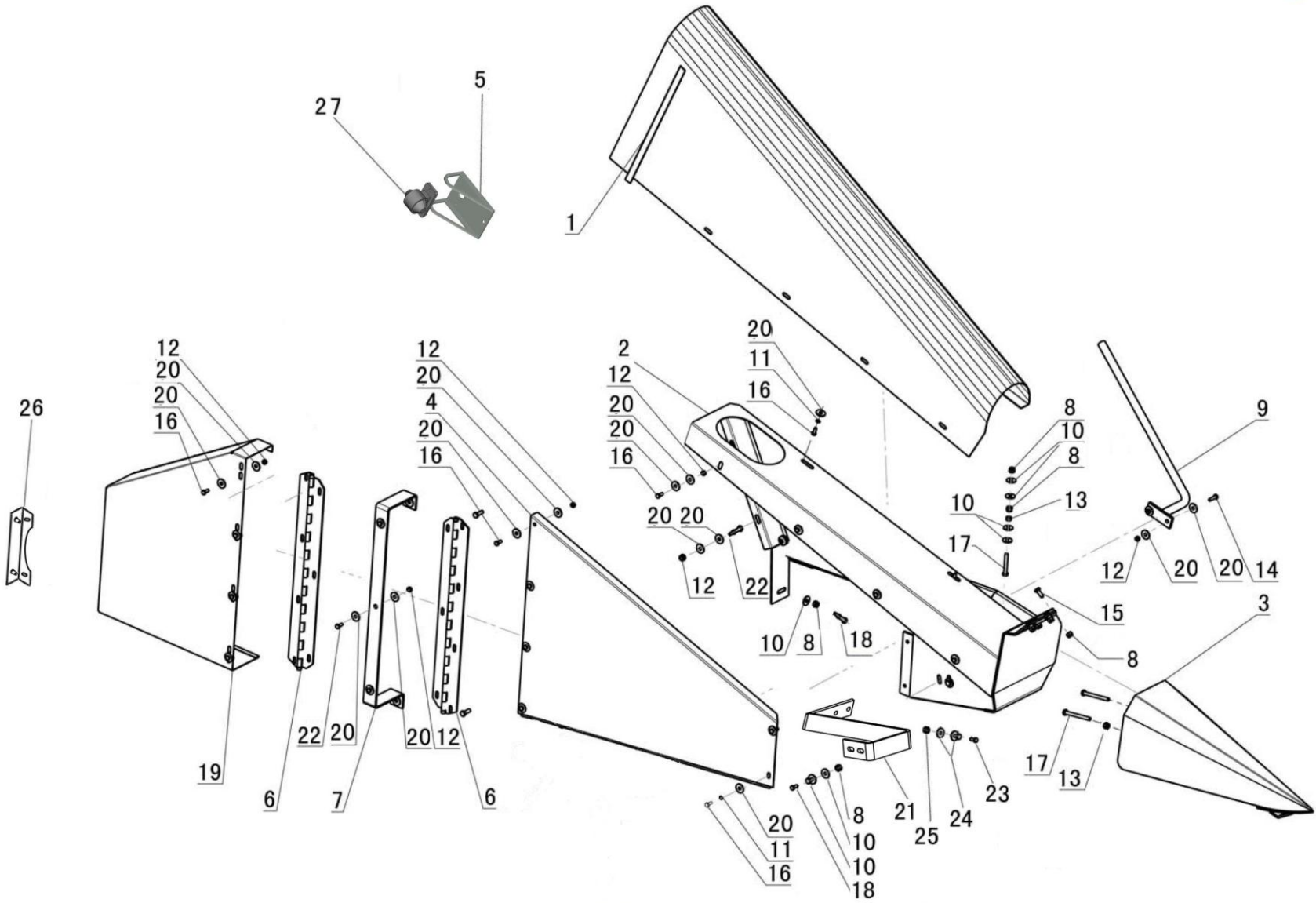



## Right Side Panels

| <u>Pos.</u> | <u>Number</u> | <u>Description</u>       | <u>Pos.</u> | <u>Number</u> | <u>Description</u>          |
|-------------|---------------|--------------------------|-------------|---------------|-----------------------------|
| 1           | 21613         | Triangular Side Cover    | 15          | 00375         | Bolt TE M10X025 UNI 5739    |
| 2           | 02389         | Right Side               | 16          | 00383         | Bolt TE M08X020 UNI 5739    |
| 3           | 02734         | Lateral tip              | 17          | 00413         | Bolt TE M10X70 UNI 5739     |
| 4           | 22178         | Front Access Cover       | 18          | 00384         | Bolt M10X30                 |
| 5           | 18423         | Light Bracket            | 19          | 20110         | Rear Access Cover L = 560mm |
| 6           | 05195         | Hinge                    | 20          | 05127         | Washer M8                   |
| 7           | 05467         | Hinge Support            | 21          | 23970         | Lateral Enclosure Bracket   |
| 8           | 04859         | Nut M10 UNI 5587         | 22          | 00377         | Bolt M8X25                  |
| 9           | 02879         | Right Deflector Tube     | 23          | 00373         | Bolt M12X35                 |
| 10          | 20533         | Washer M10               | 24          | 00947         | Washer M12                  |
| 11          | 00916         | Lock Washer M08 UNI 8842 | 25          | 04860         | Nut M12                     |
| 12          | 04858         | Nut M8 UNI 7473 AUTOB    | 26          | 18297         | Rear Latch Down Bracket     |
| 13          | 00476         | Nut M10 UNI 7473 AUTOB   | 27          | 18017         | Light Assembly              |
| 14          | 00379         | Bolt TE M08X030 UNI 5739 |             |               |                             |

# B 02

## LEFT SIDE PANELS

fantini *north america*

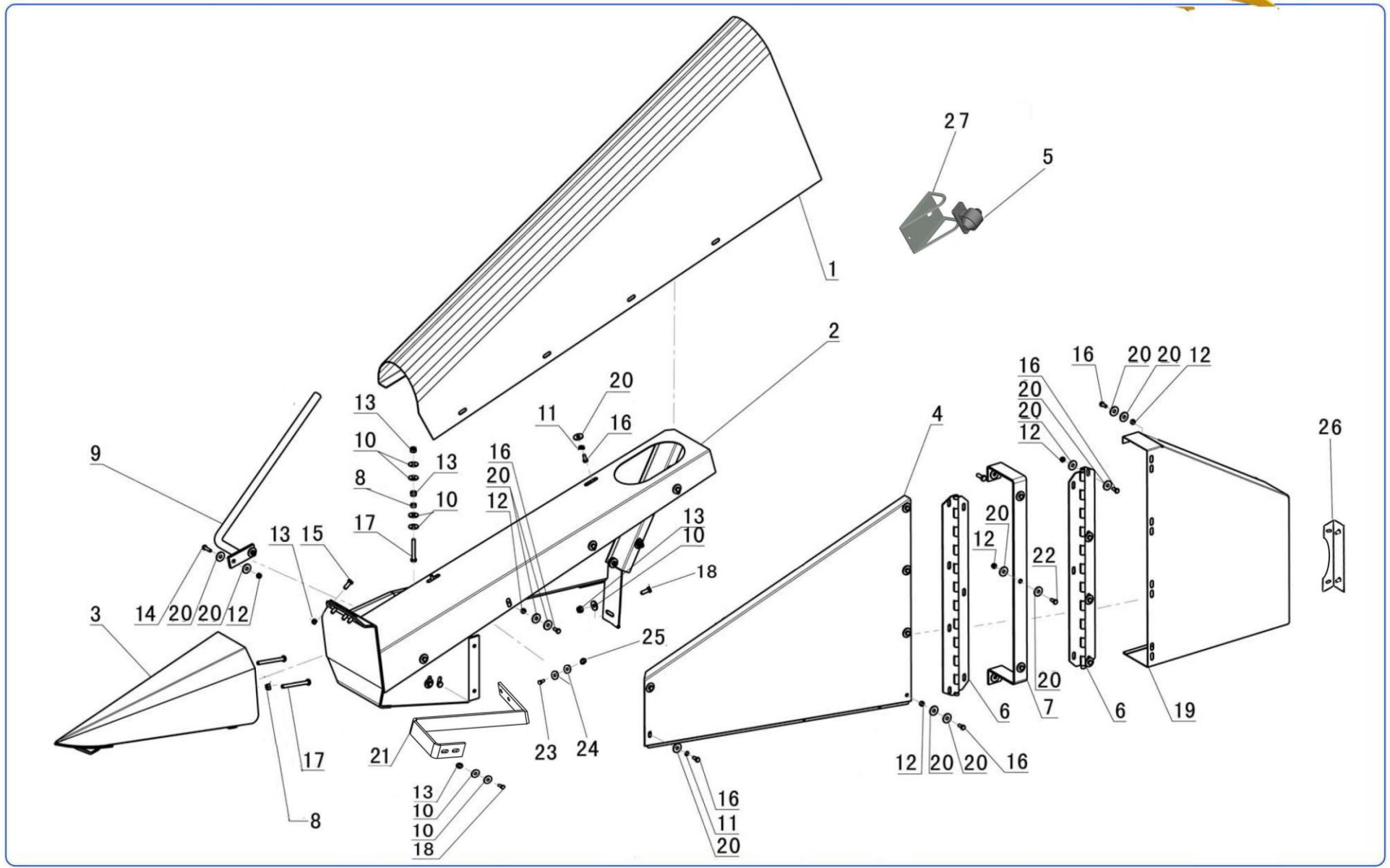

## Left Side Panels

| <u>Pos.</u> | <u>Number</u> | <u>Description</u>       | <u>Pos.</u> | <u>Number</u> | <u>Description</u>          |
|-------------|---------------|--------------------------|-------------|---------------|-----------------------------|
| 1           | 21633         | Triangular Side Cover    | 15          | 00375         | Bolt TE M10X025 UNI 5739    |
| 2           | 02391         | Lateral Enclosure        | 16          | 00383         | Bolt TE M08X020 UNI 5739    |
| 3           | 02735         | Lateral tip              | 17          | 00413         | Bolt TE M10X70 UNI 5739     |
| 4           | 22179         | Triangular Access Panel  | 18          | 00384         | Bolt M10X30                 |
| 5           | 18017         | Light Assembly           | 19          | 20111         | Back Access Cover L = 560mm |
| 6           | 05195         | Hinge                    | 20          | 05127         | Washer M08                  |
| 7           | 05467         | Hinge Bracket            | 21          | 23971         | Lateral Enclosure Bracket   |
| 8           | 00476         | Nut M10 UNI 5587         | 22          | 00377         | Bolt M8X25                  |
| 9           | 02878         | Left Deflector Tube      | 23          | 00373         | Bolt M12X35                 |
| 10          | 20533         | Washer M10               | 24          | 00947         | Washer M12                  |
| 11          | 00916         | Lock Washer M08 UNI 8842 | 25          | 04860         | Nut M12                     |
| 12          | 04858         | Nut M8 UNI 7473 AUTOB    | 26          | 18297         | Rear Latch Down Bracket     |
| 13          | 04859         | Nut M10 UNI 7473 AUTOB   | 27          | 18423         | Light Bracket               |
| 14          | 00379         | Bolt TE M08X030 UNI 5739 |             |               |                             |

**B 03**

**COLLECTING PANS**

**fantini** north america

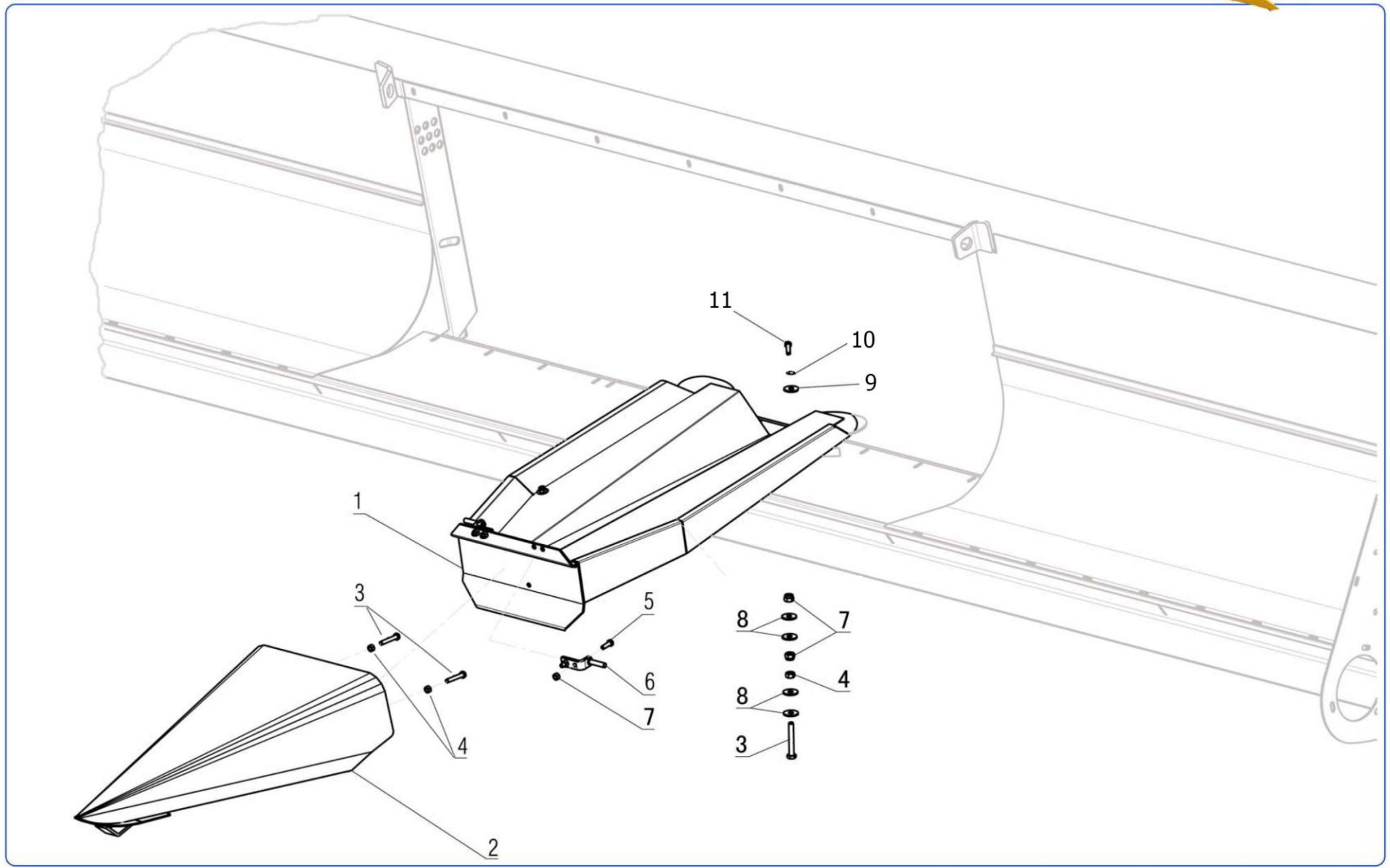

# Collecting Pans

| <u>Pos.</u> | <u>Number</u> | <u>Description</u>      |
|-------------|---------------|-------------------------|
| 1           | 02341         | Pan REG. 50             |
| 1           | 20493         | Pan REG. 56             |
| 1           | 02353         | Pan REG. 75             |
| 2           | 02754         | Point REG. 50           |
| 2           | 02756         | Point REG. 55           |
| 2           | 02765         | Point REG. 75           |
| 3           | 00413         | Bolt TE M10X70 UNI 5739 |
| 4           | 00471         | Nut M10 UNI 5587        |
| 5           | 00375         | Bolt TE M10X25 UNI 5739 |
| 6           | 03692         | Male Hinge              |
| 7           | 04859         | Nut M10 AUT UNI 7473    |
| 8           | 20533         | Washer M10              |
| 9           | 05127         | Washer M8               |
| 10          | 00916         | Lock Washer M8          |
| 11          | 00377         | Bolt M8X25              |

# C 01

## 8 ROW MESH

fantini *north america*

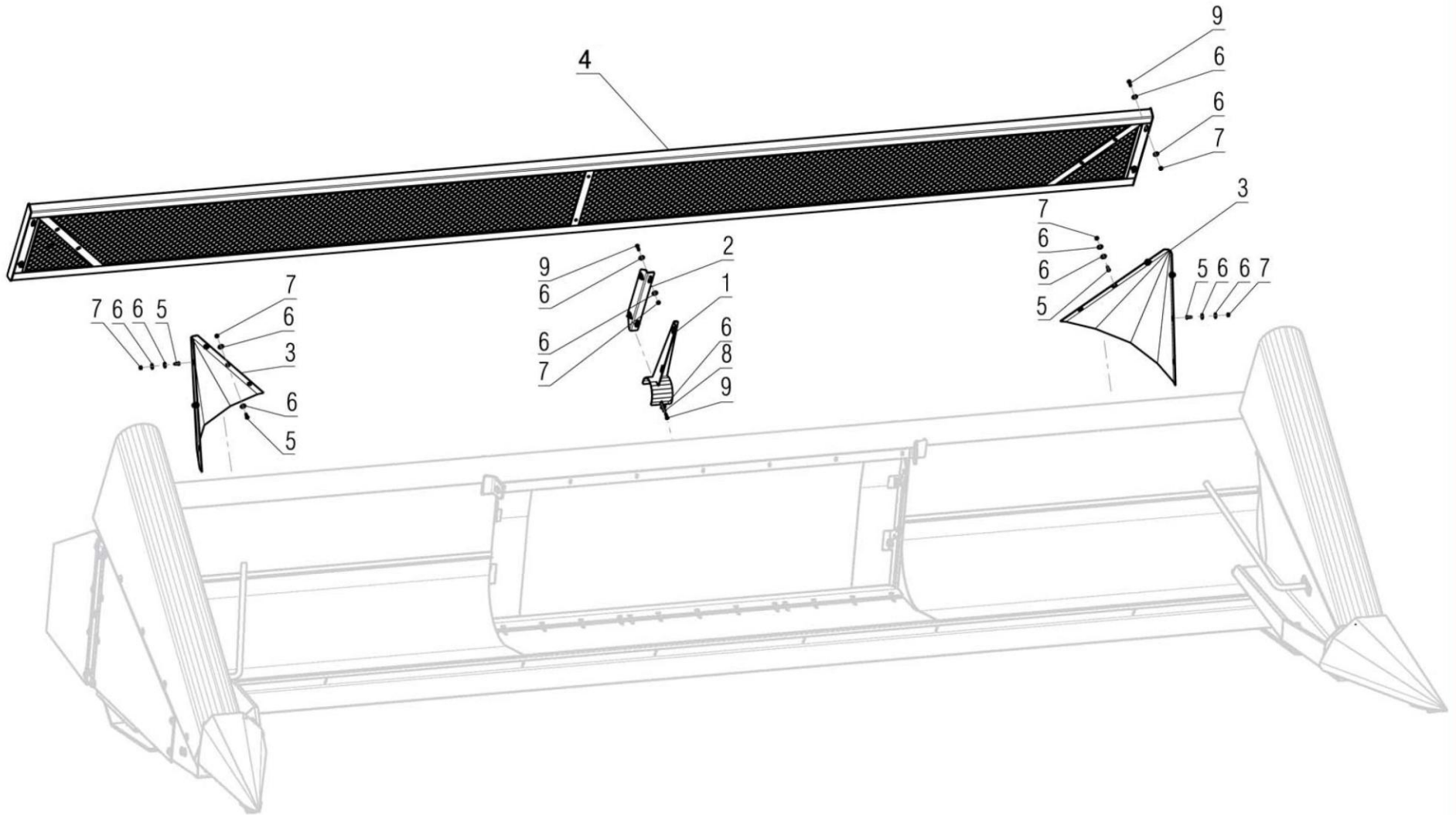

## 8 Row Mesh

| <u>Pos.</u> | <u>Number</u> | <u>Description</u>            |
|-------------|---------------|-------------------------------|
| 1           | 17423         | Mesh Support Bracket          |
| 2           | 17421         | Angle Bar for Mesh Support    |
| 3           | 21741         | Diverter Plate                |
| 4           | 07703         | Protecting Mesh 8X75 L = 5860 |
| 5           | 00377         | Bolt TE M08X25 UNI 5739       |
| 6           | 05127         | Washer 08X24X02 UNI 6593      |
| 7           | 04858         | Nut M8 UNI 7473 AUTOB         |
| 8           | 00916         | Lock Washer M08 UNI 8842      |
| 9           | 00383         | Bolt TE M08X20 UNI 5739       |

# C 02

## 12 ROW MESH

fantini *north america*

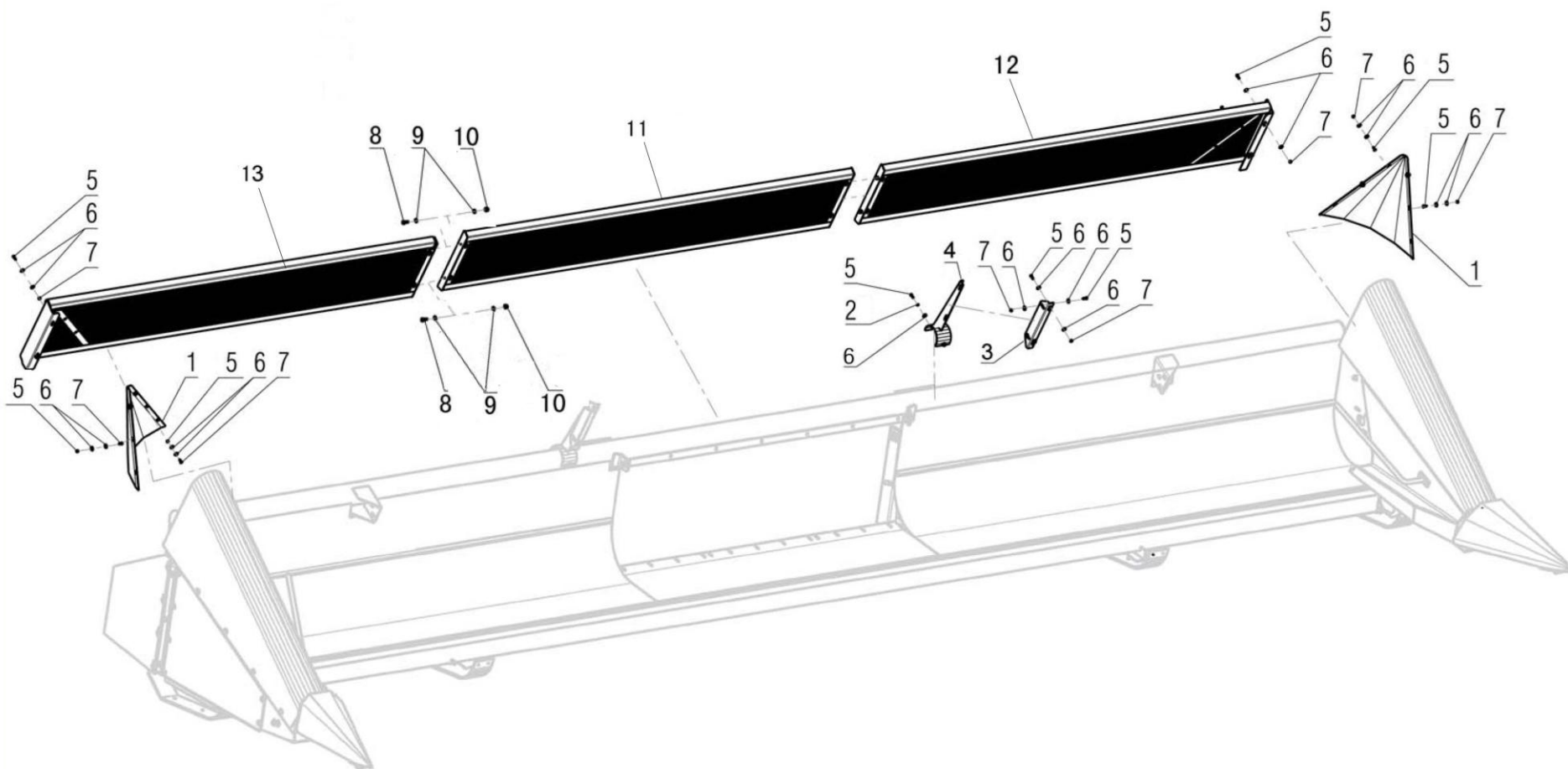



# 12 Row Mesh

| <u>Pos.</u> | <u>Number</u> | <u>Description</u>         |
|-------------|---------------|----------------------------|
| 1           | 21741         | Diverter                   |
| 2           | 00916         | Lock Washer M08 UNI 8842   |
| 3           | 17421         | Angle Bar for Mesh Support |
| 4           | 17423         | Mesh Support Bracket       |
| 5           | 00377         | Bolt TC M08X25 UNI 5931    |
| 6           | 05127         | Washer 08X24X02 UNI 6593   |
| 7           | 04858         | Nut M08 UNI 7473 AUT.      |
| 8           | 00375         | Bolt M10X25                |
| 9           | 00945         | Washer M10                 |
| 10          | 04859         | Nut M10                    |
| 11          | 22170         | Central 12X76 L = 2980     |
| 12          | 22052         | Left 12 Row L=2980         |
| 13          | 21611         | Right 12 Row L=2980        |

# D 01

## 8 ROW SIDE TRANSMISSION

fantini north america

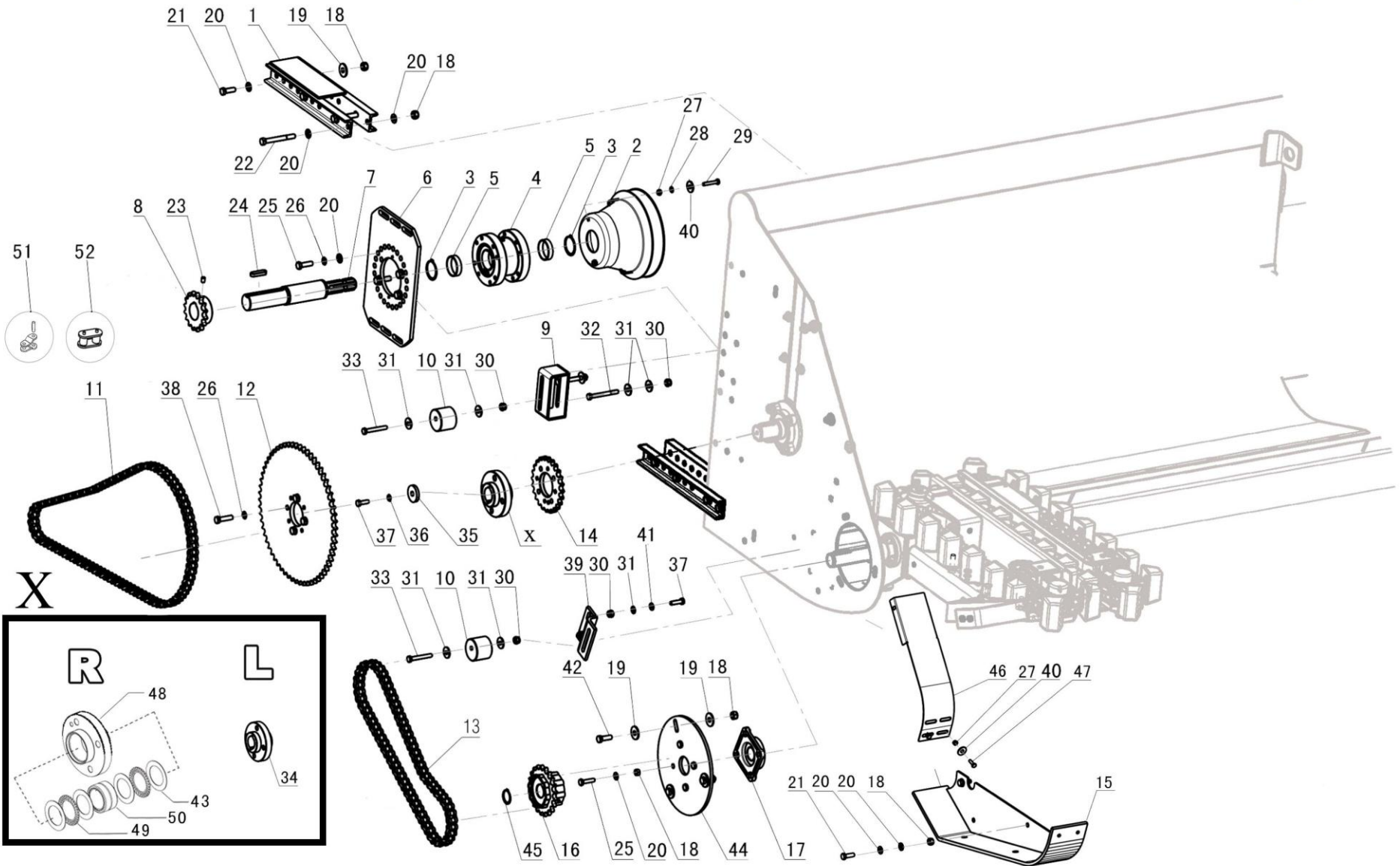

## 8 Row Side Transmission

| <u>Pos.</u> | <u>Number</u> | <u>Description</u>         | <u>Pos.</u> | <u>Number</u> | <u>Description</u>         |
|-------------|---------------|----------------------------|-------------|---------------|----------------------------|
| 1           | 14090         | Support L= 365 mm          | 13          | 03047         | Chain 34.5 Links ASA60     |
| 1           | 21740         | Support L = 410 mm         | 14          | 03418         | Z24 Ring Gear              |
| 1           | 12976         | Support L = 475 mm         | 14          | 03602         | Z26 Ring Gear              |
| 2           | 12843         | PTO Protection Shield      | 15          | 22158         | Left Skid                  |
| 3           | 09424         | Snap Ring UNI 7435 - 75    | 15          | 22157         | Right Skid                 |
| 4           | 09780         | Transmission support       | 16          | 20143         | Clutch 65dNm Z21 ASA60     |
| 5           | 11266         | Spacer                     | 17          | 01406         | Support Bearing 207        |
| 6           | 12276         | Transmission Support Plate | 18          | 04860         | Nut M12 Uni 7473           |
| 7           | 10032         | Shaft                      | 19          | 01064         | Washer 13X40X3             |
| 8           | 03251         | Z15 ASA60                  | 20          | 00947         | Washer M12 UNI 6592        |
| 8           | 03245         | Z17 ASA60                  | 21          | 00373         | Bolt M12X35 UNI 5739       |
| 8           | 03246         | Z19 ASA60                  | 22          | 11988         | Bolt TE M12X100 UNI 5737   |
| 8           | 19932         | Z20 ASA60                  | 23          | 00987         | Grub Screw M10X16 UNI 5927 |
| 8           | 03250         | Z21 ASA60                  | 24          | 00630         | Key Way 14X09X050          |
| 8           | 03261         | Z24 ASA60                  | 25          | 00439         | Bolt TE M12X40 UNI 5737    |
| 9           | 22053         | Tensioner Bracket          | 26          | 00915         | Lock Washer M12 UNI 8842   |
| 10          | 03709         | Nylon Tensioner            | 27          | 04858         | Nut M8 AUTOB UNI 7473      |
| 11          | 100831        | Chain 107 Links ASA60 Z15  | 28          | 00946         | Washer M08 UNI 6592        |
| 11          | 100830        | Chain 109 Links ASA60 Z20  | 29          | 19808         | Bolt TE M08X45 UNI 5737    |
| 11          | 100832        | Chain 111 Links ASA60 Z23  | 30          | 04859         | Nut M10 UNI 7473 AUTOB     |
| 12          | 06023         | Z 62 Ring Gear             | 31          | 20533         | Washer M10 UNI 6592        |
| 12          | 03517         | Z 70 Ring Gear             | 32          | 00401         | Bolt TE M10X95 UNI 5737    |
| 12          | 08997         | Z 75 Ring Gear             | 33          | 00393         | Bolt TE M10X75 UNI 5737    |

# D 01

## 8 ROW SIDE TRANSMISSION

fantini north america

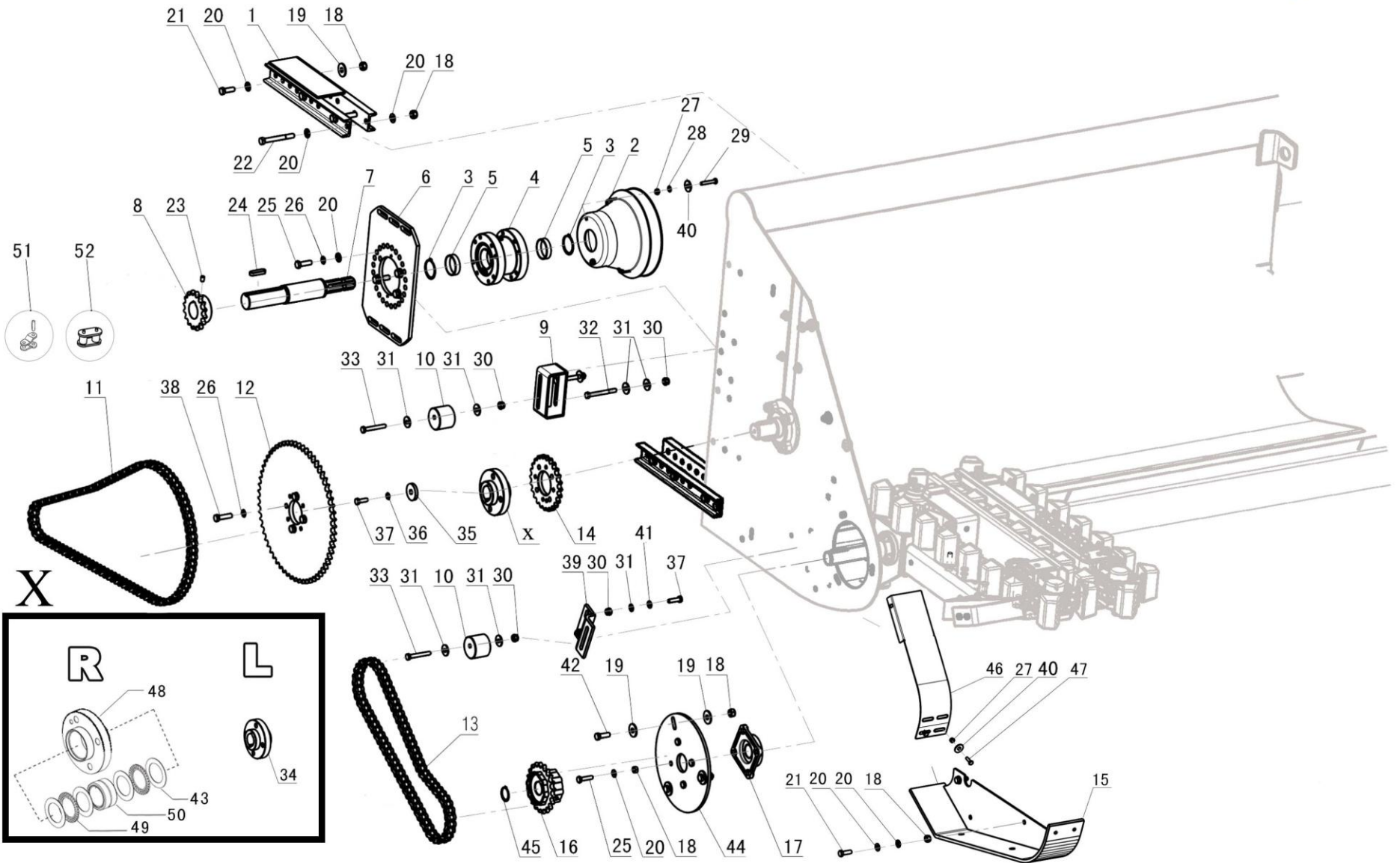

## 8 Row Side Transmission

| <u>Pos.</u> | <u>Number</u> | <u>Description</u>             |
|-------------|---------------|--------------------------------|
| 34          | 03711         | Left Ring Gear Hub             |
| 35          | 03319         | Washer 13X46X8                 |
| 36          | 00918         | Lock Washer M10 UNI 6592       |
| 37          | 00384         | Bolt M10X30 UNI 5739           |
| 38          | 05008         | Bolt TE M12X45 UNI 5738        |
| 39          | 23258         | Turnbuckle Support             |
| 40          | 05127         | Washer 08X24X02 UNI 6593       |
| 41          | 00945         | Washer M10                     |
| 42          | 00373         | Bolt TE M12X35 UNI 5739        |
| 43          | 03767         | Spacer AS4060                  |
| 44          | 13284         | Support Plate                  |
| 45          | 00604         | Snap Ring UNI 7435 - 75 EST 40 |
| 46          | 22190         | Chain Guard                    |
| 47          | 00377         | Bolt TE M08X25 UNI 5739        |
| 48          | 03097         | Right Ring Gear Hub            |
| 49          | 03766         | Bearing AXK 4060               |
| 50          | 03761         | Bearing NKJ 4030A              |
| 51          | 03114         | Half Link ASA60                |
| 52          | 03125         | Connecting Link ASA60          |

# D 02

## 12 ROW SIDE TRANSMISSION

fantini north america

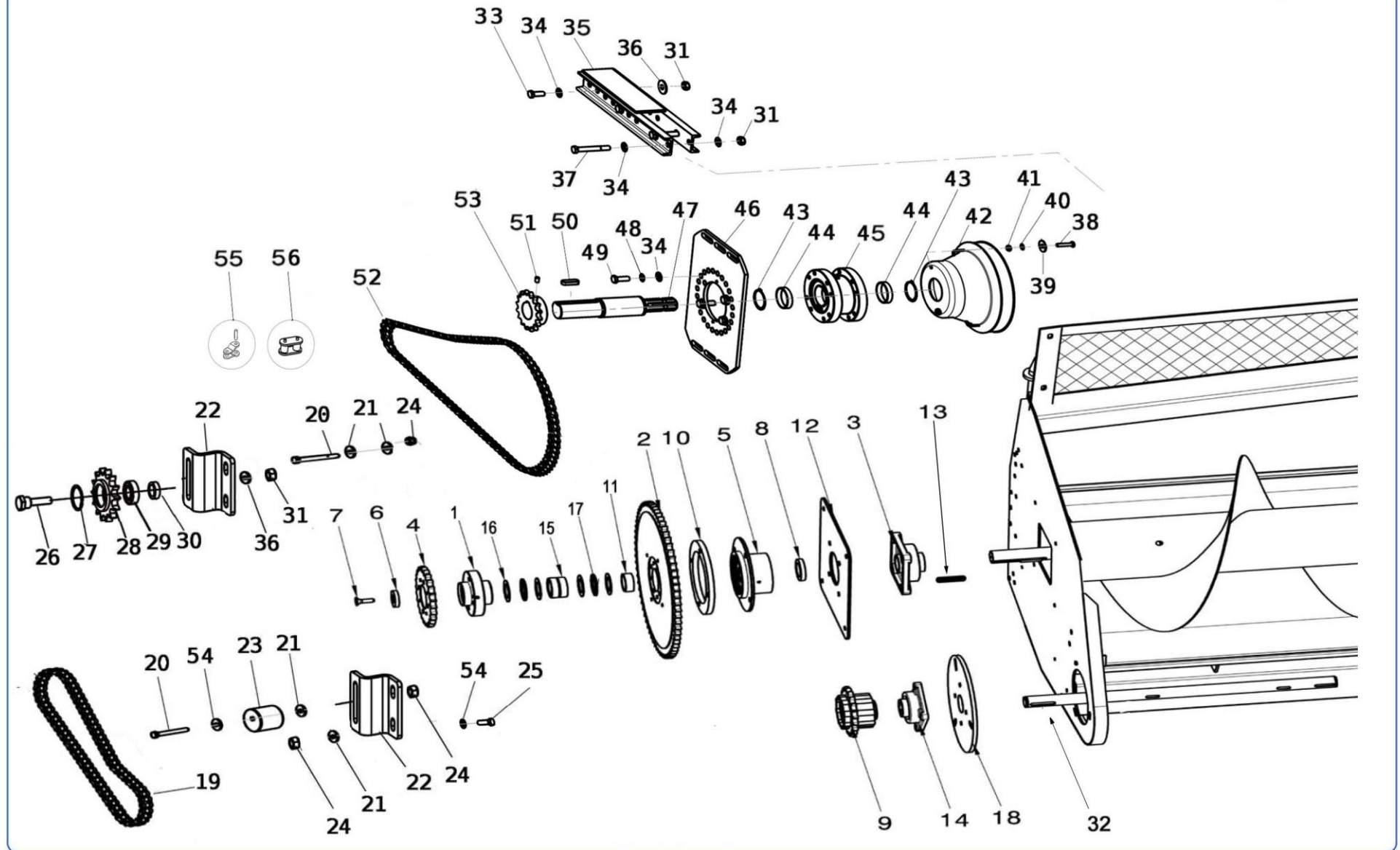

# 12 Row Side Transmission

| <u>Pos.</u> | <u>Number</u> | <u>Description</u>               | <u>Pos.</u> | <u>Number</u> | <u>Description</u>              |
|-------------|---------------|----------------------------------|-------------|---------------|---------------------------------|
| 1           | 03097         | Ring Gear Hub                    | 25          | 00384         | Bolt TE M10X030 UNI 5739        |
| 2           | 22769         | Sprocket ASA060 Z70              | 26          | 03534         | Pinion                          |
| 3           | 01355         | Support Bearing                  | 27          | 00591         | Snap Ring                       |
| 4           | 03602         | Z26 Ring Gear ASA060             | 28          | 19807         | Sprocket ASA060 Z 014           |
| 5           | 22774         | Clutch                           | 29          | 01265         | Bearing 6004-2RS                |
| 6           | 22767         | Washer                           | 30          | 06814         | Spacer 30.0X021.0-009           |
| 7           | 00511         | Bolt M10X035 UNI 5933 08.8       | 31          | 04860         | Nut M12                         |
| 8           | 23233         | Spacer 60.0X040.0-009            | 32          | 22311         | Shaft L = 777 12 Row            |
| 9           | 22923         | 90 dNm - 12 FILE                 | 33          | 00373         | Bolt M12X35 UNI 5739            |
| 10          | 22764         | Clutch Collar                    | 34          | 00947         | Washer M12 UNI 6592             |
| 11          | 22768         | Spacer 55.0X040.0-016.5          | 35          | 14090         | Transmission Support L= 365 mm  |
| 12          | 22304         | Support Plate                    | 35          | 21740         | Transmission Support L = 410 mm |
| 13          | 00607         | Key Way 10X08X050 UNI 6604-69B   | 35          | 12976         | Transmission Support L = 475 mm |
| 14          | 01406         | Support Bearing 207              | 36          | 01064         | Washer 13X40X3                  |
| 15          | 03761         | Needle Roller Bearing NKJ 4030A  | 37          | 11988         | Bolt TE M12X100 UNI 5737        |
| 16          | 03767         | Bearing Disc AS4060              | 38          | 19808         | Bolt TE M08X45 UNI 5737         |
| 17          | 03766         | Axial Needle Roller Bearing 4060 | 39          | 05127         | Washer 08X24X02 UNI 6593        |
| 18          | 12936         | Support Plate                    | 40          | 00946         | Washer M08 UNI 6592             |
| 19          | 23865         | Chain ASA60HE - 75 Links         | 41          | 04858         | Nut M8 AUTOB UNI 7473           |
| 20          | 00401         | Bolt TE M10X095 UNI 5737 08.8    | 42          | 12843         | PTO Protection Shield           |
| 21          | 20533         | Washer M10 UNI 6592              | 43          | 09424         | Snap Ring UNI 7435 - 75 EST 30  |
| 22          | 23258         | Tensioner Support                | 44          | 11266         | Spacer                          |
| 23          | 22132         | Nylon Tensioner                  | 45          | 09780         | Transmission support            |
| 24          | 04859         | Nut M10 UNI 5588                 |             |               |                                 |

# D 02

## 12 ROW SIDE TRANSMISSION

fantini north america

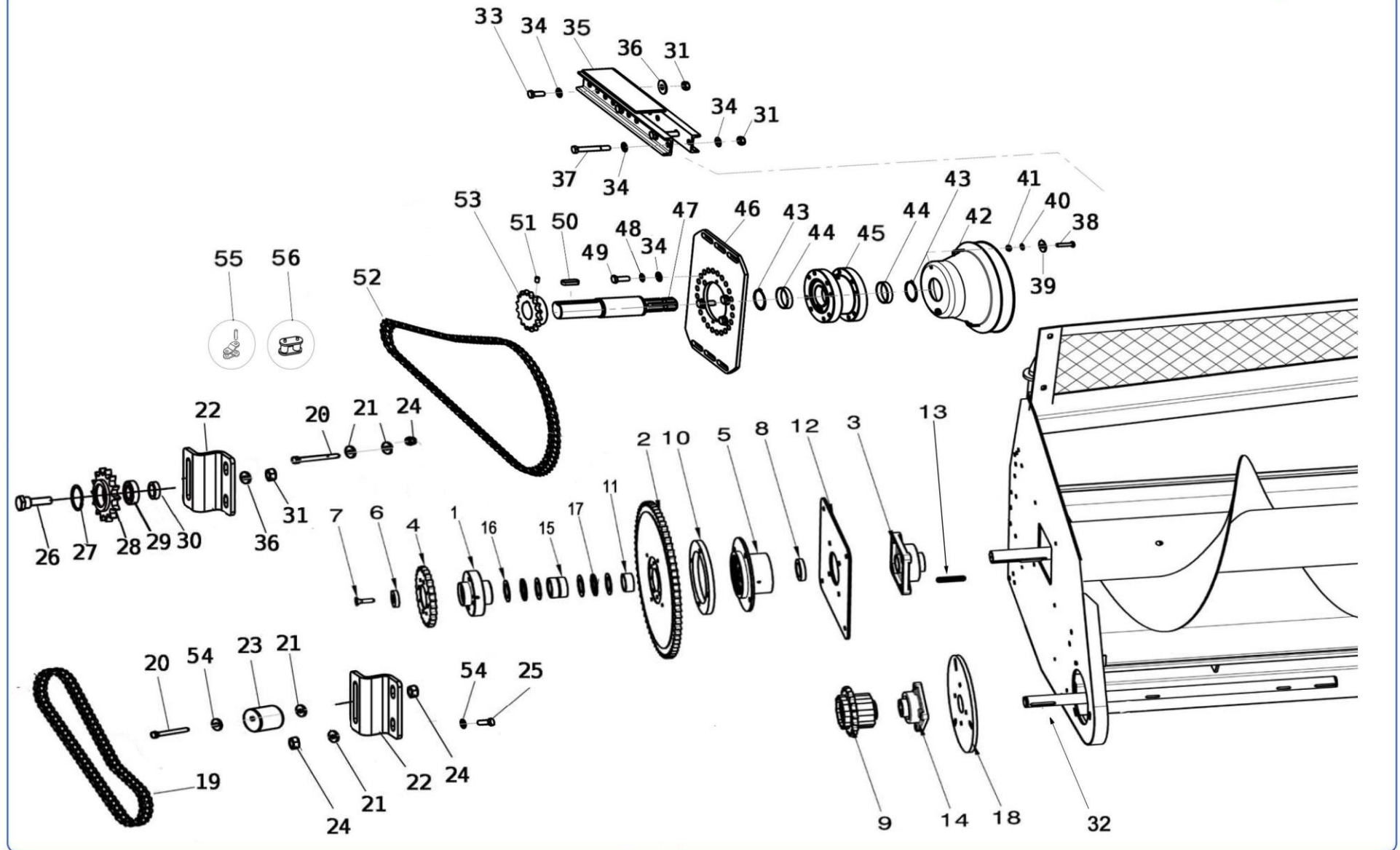



## 12 Row Side Transmission

| <u>Pos.</u> | <u>Number</u> | <u>Description</u>           |
|-------------|---------------|------------------------------|
| 46          | 12276         | Transmission Support Plate   |
| 47          | 10032         | Shaft                        |
| 48          | 00915         | Lock Washer RDE M12 UNI 8842 |
| 49          | 00439         | Bolt TE M12X40 UNI 5737      |
| 50          | 00630         | Key Way 14X09X050            |
| 51          | 00987         | Grub Screw M10X16 UNI 5927   |
| 52          | 23877         | Chain 113 Links              |
| 53          | 03251         | Z15 ASA60                    |
| 53          | 03245         | Z17 ASA60                    |
| 53          | 03246         | Z19 ASA60                    |
| 53          | 19932         | Z20 ASA60                    |
| 53          | 03250         | Z21 ASA60                    |
| 53          | 03261         | Z24 ASA60                    |
| 54          | 00945         | Washer M10                   |
| 55          | 03114         | Half Link ASA60              |
| 56          | 03125         | Connecting Link ASA60        |

D 03

12 ROW REAR TRANSMISSION

fantini north america

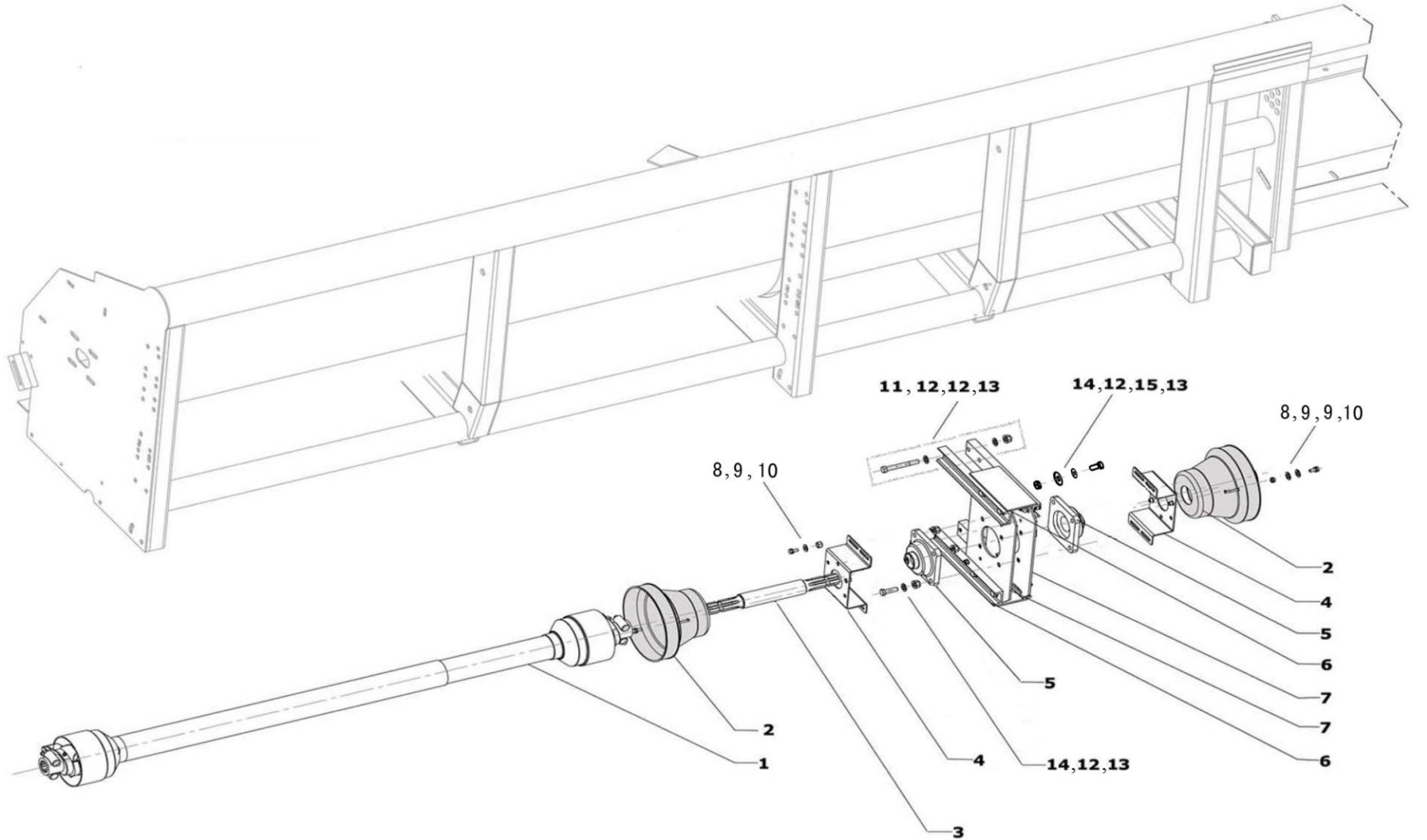

## 12 Row Rear Transmission

| <u>Pos.</u> | <u>Number</u> | <u>Description</u>             |
|-------------|---------------|--------------------------------|
| 1           | 14803         | PTO Shaft V60 3/8 Z6 L=1450    |
| 2           | 12843         | PTO Protection Shield          |
| 3           | 18081         | Shaft                          |
| 4           | 18113         | Support for PTO Shield         |
| 5           | 01411         | Support Bearing                |
| 6           | 14090         | Transmission Support Arm L+365 |
| 7           | 18112         | Transmission Support Plate     |
| 8           | 00383         | Bolt M8X20                     |
| 9           | 05127         | Washer 08X24X02 UNI 6593       |
| 10          | 04858         | Nut M8                         |
| 11          | 11988         | Bolt TE M12X100 UNI 5737       |
| 12          | 00947         | Washer M12 UNI 6592            |
| 13          | 04860         | Nut M12 Uni 7473               |
| 14          | 00373         | Bolt M12X35                    |
| 15          | 01064         | Washer 13X40X3                 |

# D 04

## DRIVE SHAFT

fantini *north america*

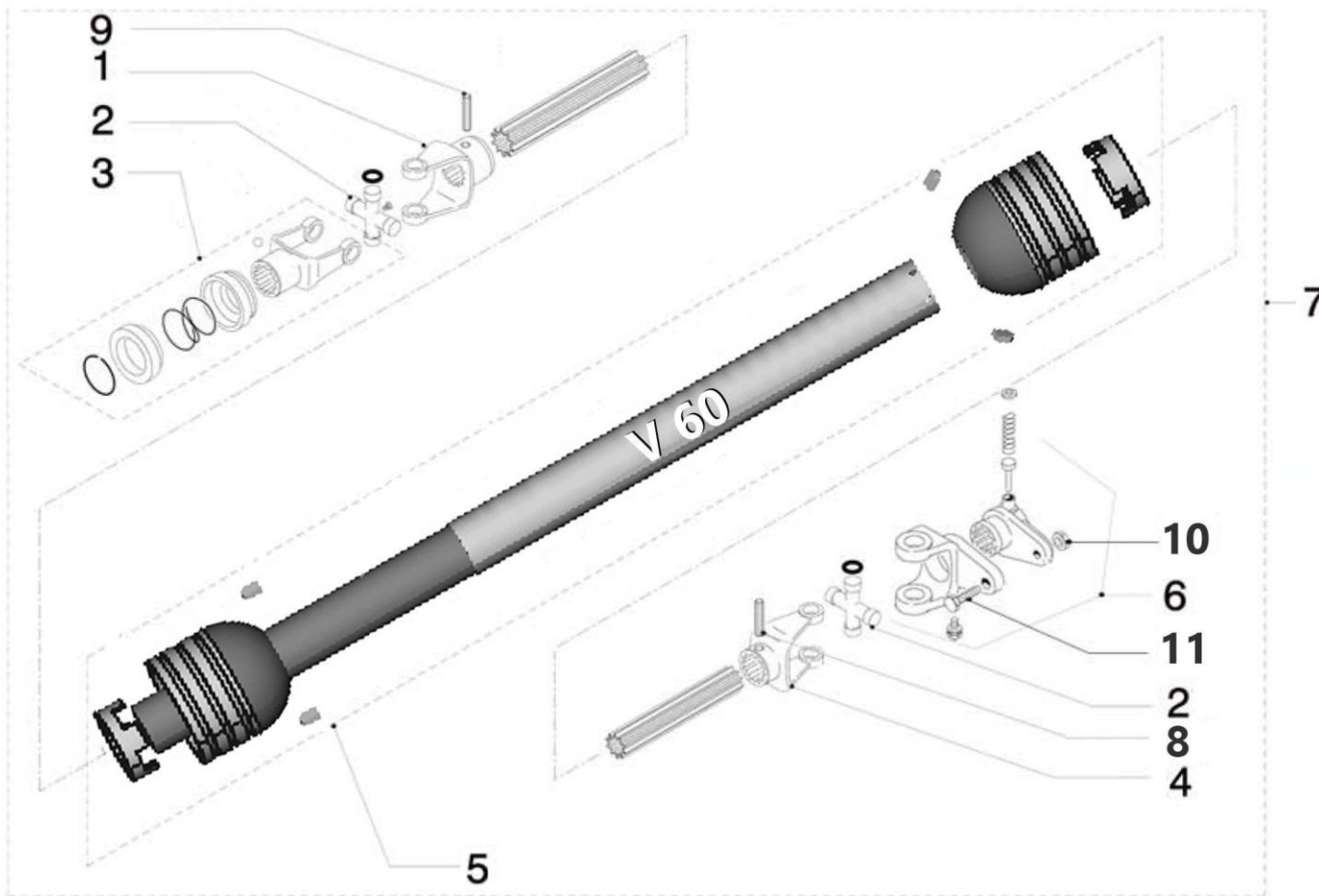

# Drive Shafts

| <u>Pos.</u> | <u>Number</u> | <u>Description</u>                      |
|-------------|---------------|---|
| 1           | 14888         | Fork                                    |
| 2           | 14745         | Cross for PTO                           |
| 3           | 13960         | V60 1"3/8 Z21                           |
| 3           | 13959         | V60 1"3/8 Z6                            |
| 3           | 13962         | Fork V60 ESA. 27                        |
| 3           | 13961         | Fork V60 ESA. 28.5                      |
| 4           | 14889         | Fork                                    |
| 5           | 16227         | PTO Safety Cover Complete V60 L = 1770  |
| 6           | 14893         | Shear Bolt Fork                         |
| 7           | 14803         | PTO Shaft V60 Z6 + Z6 L = 1450          |
| 7           | 14282         | PTO Shaft V60 Z6 + Z21 L = 1450         |
| 7           | 14801         | PTO Shaft V60 Z6 + E 28.5 Hex. L = 1450 |
| 7           | 14294         | PTO Shaft V60 Z6 + E 27 Hex. L = 1450   |
| 7           | 17557         | PTO Shaft V60 Z6 + Z21 L=1970 (Gleaner) |
| 8           | 19960         | Roll Pin 10X90 DIN 1481                 |
| 9           | 00999         | Roll Pin 10X80 DIN 1481                 |
| 10          | 04859         | Nut M10 UNI 7473                        |
| 11          | 00385         | Bolt TE M10X060 UNI 5739 08.8           |

# E 01

## 8 ROW AUGER

fantini *north america*

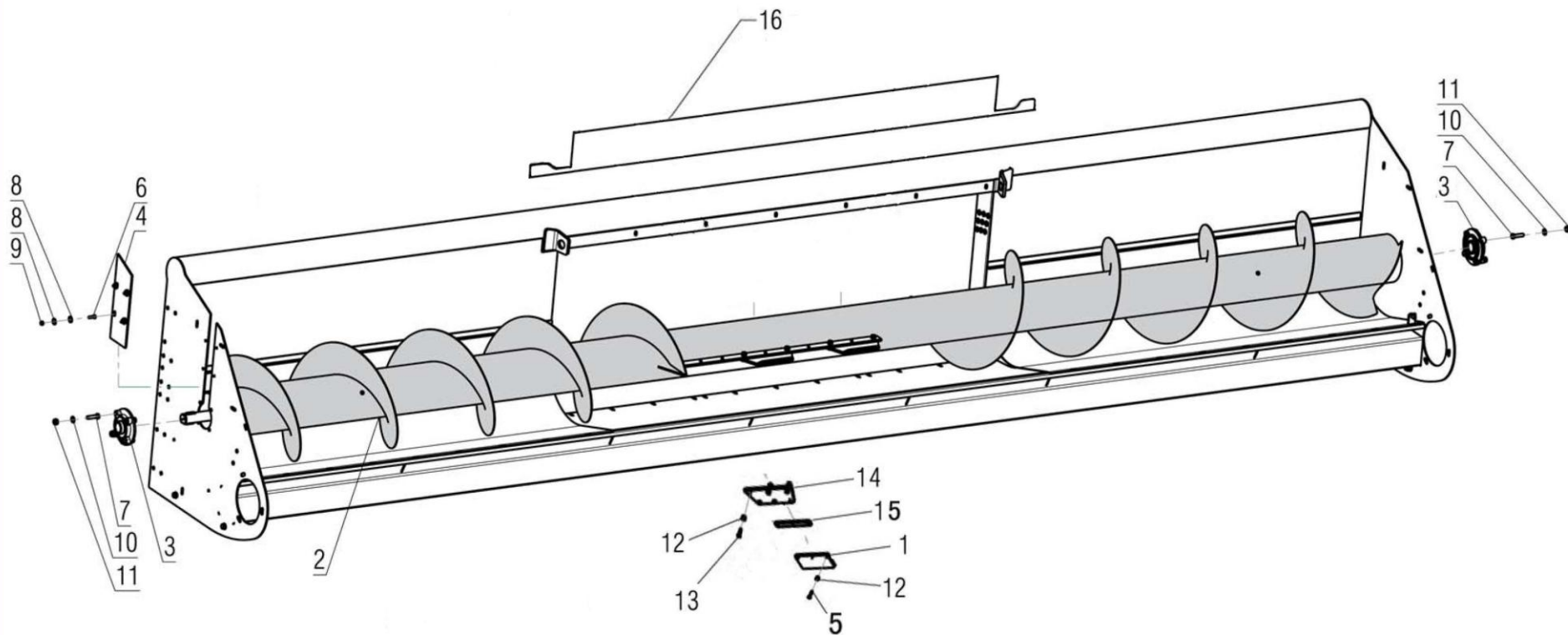

# 8 Row Auger

| <u>Pos.</u> | <u>Number</u> | <u>Description</u>     |
|-------------|---------------|------------------------|
| 1           | 21941         | Rubber Flap            |
| 2           | 19299         | Auger 8X76 L = 5900    |
| 3           | 01410         | Support Bearing        |
| 4           | 02945         | Metal Sheet            |
| 5           | 00403         | Bolt M10X35 UNI 5739   |
| 6           | 00377         | Bolt M08X25 UNI 5739   |
| 7           | 00450         | Bolt M12X40 UNI 5737   |
| 8           | 05127         | Washer M08 UNI 6592    |
| 9           | 04858         | Nut M8 UNI 7473 AUTOB. |
| 10          | 00947         | Washer M12 UNI 6592    |
| 11          | 04860         | Nut M12 UNI 7473 AUTOB |
| 12          | 04859         | Nut M10                |
| 13          | 00384         | Bolt M10X30            |
| 14          | 21980         | Rubber Flap Plate      |
| 15          | 21979         | Brace                  |
| 16          | 17417         | Center Guard           |

# E 02

## 12 ROW TWO PIECE AUGER

fantini *north america*

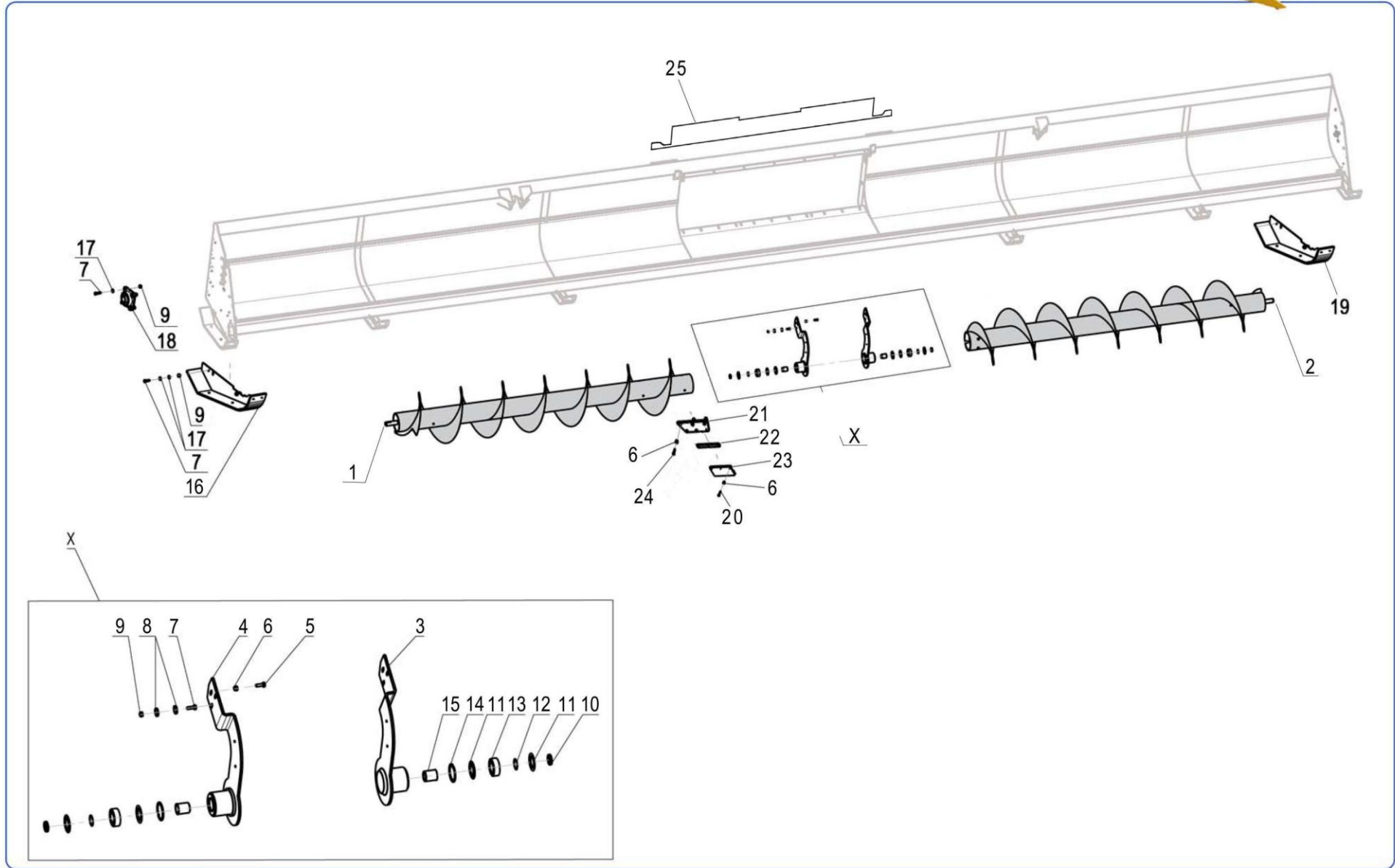



# 12 Row Two Piece Auger

| <u>Pos.</u> | <u>Number</u> | <u>Description</u>           |
|-------------|---------------|------------------------------|
| 1           | 23040         | Auger Right 12x76            |
| 2           | 23039         | Auger Left 12x76             |
| 3           | 22288         | Left Support Bracket         |
| 4           | 22287         | Right Support Bracket        |
| 5           | 00333         | Bolt M10X30 UNI 5739         |
| 6           | 04859         | Nut M10 UNI 7473             |
| 7           | 00450         | Bolt M12X40 UNI 5737         |
| 8           | 09361         | Washer 33X13X5               |
| 9           | 04860         | Nut M12 UNI 7473             |
| 10          | 22235         | Spacer 42X35-6               |
| 11          | 01330         | Nylon Washer 6207 JV         |
| 12          | 01038         | Spacer 35X45X25              |
| 13          | 01287         | Bearing 2207-2RS             |
| 14          | 19479         | Snap Ring INT. Ø 72 UNI 7438 |
| 15          | 23432         | Spacer 42X35-45              |
| 16          | 21921         | Right Skid Plate             |
| 17          | 00947         | Washer M12 UNI 6592          |
| 18          | 01410         | Support Bearing GRA. D40     |
| 19          | 21922         | Left Skid Plate              |
| 20          | 00403         | Bolt M10X35                  |
| 21          | 21980         | Extension Plate              |
| 22          | 21979         | Brace                        |
| 23          | 21941         | Rubber Flap                  |
| 24          | 00384         | Bolt M10X30 UNI 5739         |
| 25          | 24012         | Center Shield                |

# E 03

## 12 ROW THREE PIECE AUGER

fantini north america



# UP TO 2012

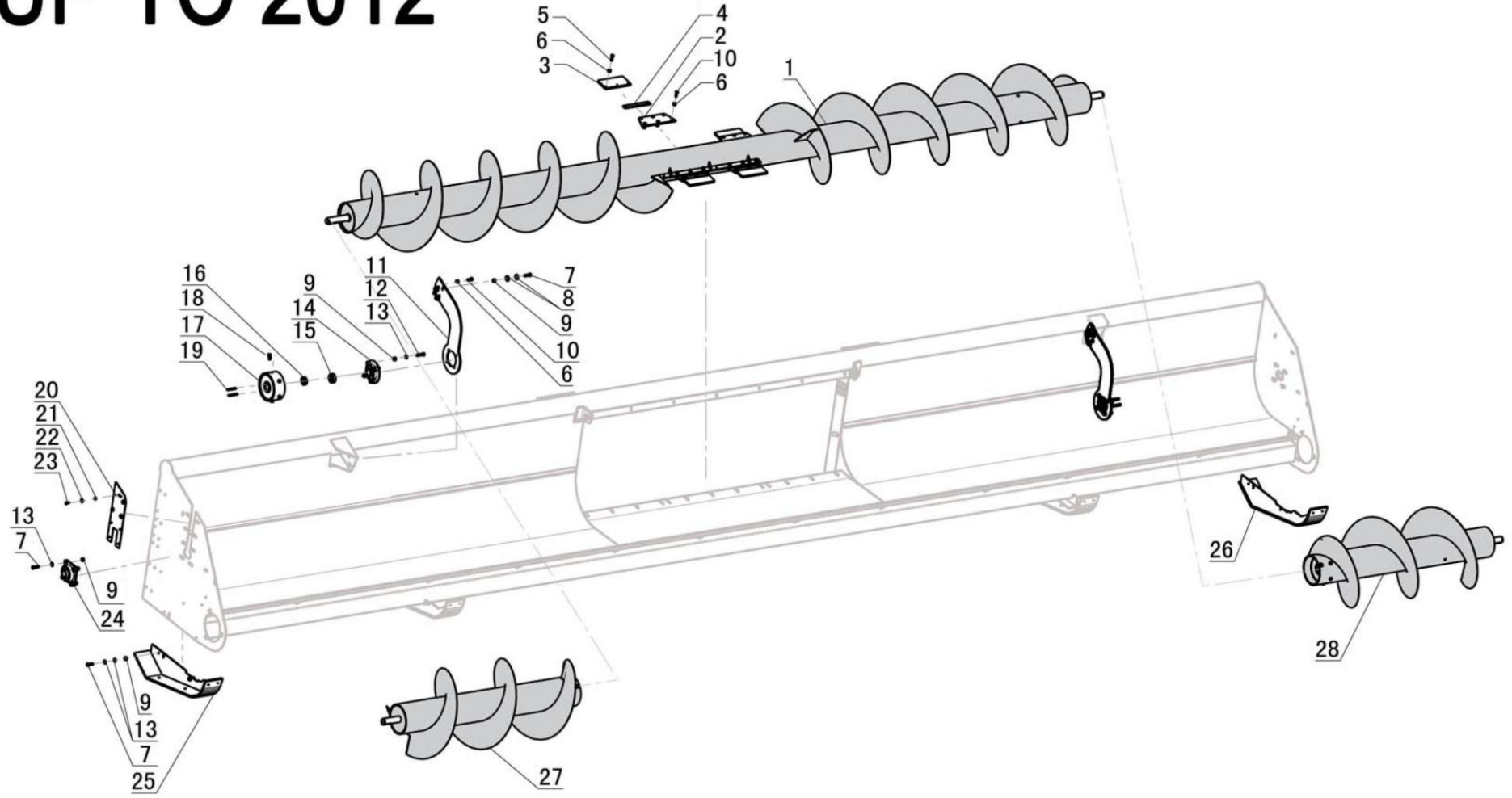

# 12 Row Three Piece Auger

| <u>Pos.</u> | <u>Number</u> | <u>Description</u>        | <u>Pos.</u> | <u>Number</u> | <u>Description</u>              |
|-------------|---------------|---------------------------|-------------|---------------|---------------------------------|
| 1           | 16012         | Auger Central 12 Row      | 15          | 21976         | Spacer for Auger-Frame          |
| 2           | 21979         | Rubber Flap Plate L = 196 | 16          | 09529         | Spacer 45X40-27                 |
| 3           | 21941         | Rubber Flap L = 192       | 17          | 19744         | Complete Bushing for Side Auger |
| 4           | 21980         | Rubber Flap Brace L = 256 | 18          | 00371         | Bolt M12X30 UNI 5739            |
| 5           | 00403         | Bolt TE M10X35 UNI 5739   | 19          | 21690         | Key Ways 10X08X070              |
| 6           | 04859         | Nut M10 UNI 7473 AUT      | 20          | 02945         | Metal Sheet                     |
| 7           | 00450         | Bolt M12X40 UNI 5737      | 21          | 04858         | Hex Nut M8 UNI 7473 AUT         |
| 8           | 01064         | Washer M12 UNI 6592       | 22          | 05127         | Washer M08 UNI 6592             |
| 9           | 04860         | Nut M12 UNI 7473 AUT      | 23          | 00377         | Bolt M8X25                      |
| 10          | 00384         | Bolt M10X30 UNI 5739      | 24          | 01410         | Support Bearing                 |
| 11          | 17799         | Support Arm               | 25          | 21921         | Right Skid                      |
| 12          | 00390         | Bolt M12X50 UNI 5737      | 26          | 21922         | Left Skid                       |
| 13          | 00947         | Washer M12 UNI 6592       | 27          | 19594         | Right 12X76 LG.1656 Auger       |
| 14          | 13788         | Support Bearing           | 28          | 19595         | Left 12X76 LG.1656 Auger        |