

fantini

the best harvest since 1968



fantiniworld.com



Model

GH3-G03

CATALOGO RICAMBI 
ERSATZTEILEKATALOG 
SPARE PARTS CATALOGUE 
КАТАЛОГ ЗАПАСНЫХ ЧАСТЕЙ 
CATALOGUE DES PIECES DE RECHANGE 

(NORTH AMERICA EDITION)

Spare Parts Catalogue: Mod. GH3 - G03

Release: 010

MAY 2016

fantini
the best harvest since 1968

 **COME USARE IL CATALOGO RICAMBI FANTINI NORTH AMERICA**
 **HOW TO USE FANTINI NORTH AMERICA SPARE PARTS CATALOGUE**
 **COMMENT UTILISER LES CATALOGUES PICES FANTINI NORTH AMERICA**
 **GEBRAUCHSANWEISUNGEN VOM FANTINI NORTH AMERICA ERSATZTEILKATALOG**

- Per ragioni di semplificazioni il catalogo è stato creato senza testo indicando le UNI.
La colonna della quantità indica quante volte tale ricambio si ripete all'interno dell'esplosivo.
- For the sake of simplicity the spare parts catalogue contains only UNI identifications.
The section of quantity shows the repetition of that spare part in the table.
- Pour raisons de simplifications le catalogue a été créé sans texte en indiquant les UNI.
La colonne de la quantité indique combien de même rechange se répète à l'intérieur de l'explosé.
- Zwecks der Verständlichkeit erscheint der Ersatzteilkatalog nur mit UNI-Angaben.
Der Abschnitt der Quantität beinhaltet die Häufigkeit solches Ersatzteiles in der Tafel.

P.	CODICE Code	Qt.	DENOMINAZIONE Description	NOTE
Numero di identificazione ID number	Codice ricambio Spare part code	Quantità di pezzi Quantity of spare parts	Identificazione UNI UNI identification	
Nombre de identification ID Nummer	Code de Rechange Ersatzteilkode	Quantite de Parts Ersatzteilequantität	Identification Uni UNI-Angabe	

DENOMINAZIONE

Reg. 70 cm	Distanza File 70 cm	70cm Row width	Distance entre elements 70cm	70 cm Reihenabstand
12 File	Numero di file 12	12 rows	Nombre de lignes 12	12 Reihe
R	Destro	Right	Arbre	Rechts
L	Sinistro	Left	Droit	Links
C	Centrale	Central	Central	Zentral
L Base - R Base	Punte Centrali fisse	Fixed central tips	Point central fix	Starre zentrale Spitzen
Lat.	Laterale	Lateral	Lateral	Seitlich
Rib.	Ribaltabile	Folding	Repliable	Klappbar
Fis.	Fisso	Fix	fix	Starr
L.E.	Lame Elettriche	Electric blades	Lames électriques	Elektrische Messer
Maschio	Maschio	Male	Male	Feder
Femmina	Femmina	Female	Female	Nut

2

19160

1

10x75

Numero di file 10
Number of rows 10
Nombre de lignes 10
Reihenanzahl 10

Distanza File 75 cm
Row width 75 cm
Distance entre elements 75
Reihenabstand 75



N° di Tavola e pagina, Table end page number, N° de Table et page, N° von tafel und seitezahl

Categoria (Cofanatura), Category (Bonnets), Catégorie (coffres), Kategorie (Hauben)

fantini

the best harvest since 1968

FANTINI NORTH AMERICA LLC
15526 90th Street NE - Drayton, ND 58225
P 1-800-454-3875
fantini-na.com

Serial Number:

--	--	--	--	--	--	--	--



Il seguente manuale e i suoi allegati non possono essere manomessi o modificati, riprodotti né ceduti a terzi senza l'autorizzazione della **FANTINI NORTH AMERICA LLC**. Certa della Vostra soddisfazione per ogni chiarimento e collaborazione la **FANTINI NORTH AMERICA LLC** augura Buon Lavoro! Il manuale va conservato con cura per tutta la durata della macchina, di cui è parte integrante; è quindi indispensabile nel caso di cessione della macchina accertarsi che vengano consegnati il manuale e tutti gli allegati (schemi, lay-out, fondazioni, ecc.). **Le indicazioni riportate nel presente manuale non sostituiscono le disposizioni di sicurezza e i dati tecnici, per l'installazione e il funzionamento, applicate direttamente sul prodotto**, né tantomeno le norme di sicurezza vigenti nel paese di installazione e le regole dettate dal comune buon senso. È comunque necessario considerare che questo documento non può sopperire a carenze tecniche o intellettive che operatori e manutentori devono comunque possedere.



This handbook and its annexes may not be tampered with or modified, copied or given to third parties without **FANTINI NORTH AMERICA LLC's** authorization. We are sure you will be pleased with your purchase, and are always at your service for any explanations or assistance you may require. **FANTINI NORTH AMERICA LLC** wish you good work! The handbook must be kept in a safe place throughout the working life of the machine, of which it forms an integral part. If the machine is sold on, ensure that the handbook and all the annexes (diagrams, layouts, foundation drawings etc.) are also consigned. **The information in this handbook does not replace the safety regulations and technical data for installation and operation applied directly to the machine**, the safety norms in force in the country of installation, or the rules dictated by common sense. Bear in mind that this document cannot compensate for the shortcomings of operatives or maintenance staff who do not have the necessary technical skills or mental abilities.



Le présent manuel et ses annexes ne peuvent être ni endommagés ni modifiés, ni copiés ni cédés à des tiers sans l'autorisation de la société **FANTINI NORTH AMERICA LLC**. Certains de vous satisfaire et à votre disposition pour toute information et collaboration, **FANTINI NORTH AMERICA LLC** vous souhaite bon travail! Le manuel doit être conservé soigneusement pour toute la durée de vie de la machine dont il fait partie intégrante. Il est par conséquent indispensable, en cas de cession de la machine, de s'assurer de la remise du manuel et de toutes les annexes (schémas, lay-out, fondations, etc.). **Les indications rapportées dans le présent manuel ne remplacent pas les dispositions de sécurité et les données techniques, pour l'installation et le fonctionnement, appliquées directement sur le produit**, ni d'ailleurs les normes de sécurité en vigueur dans le pays d'installation et les règles dictées par le bon sens commun. Il est nécessaire de considérer que ce document ne peut faire face aux carences techniques ou intellectuelles des opérateurs.



Es ist verboten das folgende Katalog und seine Anlage ohne Genehmigung von der Firma **FANTINI NORTH AMERICA LLC** zu fälschen, verändern, vervielfältigen oder es zugunsten Dritter zu überlassen. Wir stehen gerne für Erklärungen und Wartung zur Verfügung und wir wünschen Ihnen viel Erfolg! Es ist nötig, das Katalog für die ganze Lebensdauer des Pflückers sorgfältig zu behalten, da es sein integrierender Bestandteil ist. Im Fall von Übertragung des Pflückers müssen auch das Katalog und seine Anlage (Schemen, Zeichnungen) weitergegeben werden. **Die im Katalog enthaltenen Informationen ersetzen weder Sicherheitsbestimmungen und technische Daten für Montage und Lauf des Pflückers (die direkt auf den Pflücker zu finden sind), noch gültige Sicherheitsmaßnahmen im Land**, wo der Pflücker verwendet wird, noch Regeln gesundes Menschenverstandes. Dieses Katalog ist nicht in der Lage, technische oder intellektuelle Unzulänglichkeiten auszugleichen, dieman für Benutzung und Wartung besitzen muss.

INDICE - INDEX

A

**PUNTA
TIP
POINTE
SPITZE**

- A 01** Forcella SX - Left fork - Fourche - Linke gabel
- A 02** Forcella Dx - Right fork - Fourche - Rechte Gabel
- A 03** Punta G03-GH3 - Row unit G03-GH3 - Chaîne av dents G03-GH3 - Pflückeinheit G03-GH3
- A 04** Catena con dentoni in Gomma - Chain with rubber teeth - Chaîne av dents en caoutchouc - Kette mit Gummizähnen
- A 05** Collegamenti gruppo punte G03 - Row units connection G03 - Connections entre rangs - Verbindung der Pflückeinheit G03
- A 06** Collegamenti gruppo punte GH3 - Row units connection GH3 - Connections entre rangs - Verbindung der Pflückeinheit GH3
- A 07** Albero gruppo punte GH3 - Row units connections shafts GH3 - Arbre de connections - Verbindungswellen der Pflückeinheit GH3

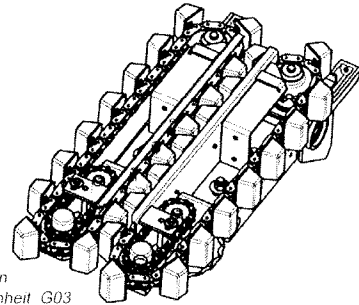

B

**LEVE PER CHIUSURA TELAIO
WHEEL PROTECTOR
PLAQUE COMPACTEUR
STENDELKNICKER**

- B 01** Leve per chiusura Telaio GH3 - Frame folding levers GH3 - Levier pour fermeture Chassis - Hebel für Klappen des Rahmens GH3
- B 02** Leve per chiusura Telaio 12 file - 12-rows frame folding levers GH3 - 12 rangs Levier pour fermeture Chassis - Hebel für Klappen des 12-reihigen rahmens GH3

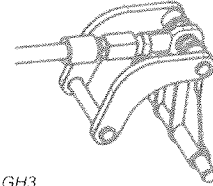

C

**COFANI
BONNET
COFFRES
HAUBEN**

- C 01** Cofananatura laterale dx G03 - Right side bonnet G03 - Capot lateral droite G03 - Rechte Seitenhaube G03
- C 02** Cofananatura laterale sx G03 - Left side bonnet G03 - Capot lateral gauche G03 - Linke Seitenhaube G03
- C 03** Cofananatura laterale dx GH3 - Right side bonnet GH3 - Capot lateral droite GH3 - Rechte Seitenhaube GH3
- C 04** Cofananatura laterale sx GH3 - Left side bonnet GH3 - Capot lateral gauche GH3 - Linke Seitenhaube GH3
- C 05** Cofananatura centrale G03 - Central bonnets G03 - Capot central G03 - Zentrale hauben G03
- C 06** Cofananatura centrale GH3 - Central bonnets GH3 - Capot central GH3 - Zentrale hauben GH3
- C 07** Reti GH3 - Net GH3 - Gril de protection GH3 - Netz GH3
- C 08** Reti G03 - Net G03 - Gril de protection G03- Netz G03
- C 09** Reti 12 file G03 - 12-rows net G03 - Gril de protection 12 éléments G03 - 12-reihiges netz G03

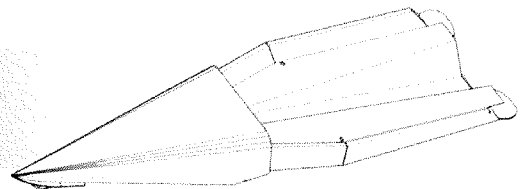

F

**TRASMISSIONE
TRANSMISSION
TRANSMISSION
ANTRIEB**

- F 01** Trasmissione Dx - Right transmission - Droite transmission - Rechter Antrieb
- F 02** Trasmissione Sx - Left transmission - Gauche transmission - Linker Antrieb
- F 03** Trasmissione laterale G03 - Side transmission G03 - Trasmission lateral G03 - Seitenantrieb G03
- F 04** Trasmissione laterale GH3 - Side transmission GH3 - Trasmission lateral GH3 - Seitenantrieb GH3
- F 05** Cardani V60/V80-giunti - Drive shafts V60/V80-joints - Cardan V60/V80 jointe - Kardanwelle V60/V80 Verbindungen

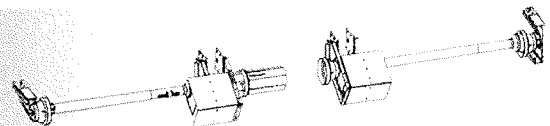

I

**COCLEE
AUGER
VIS
SCHNECKE**

- I 01** Coclee G03 - Auger G03 - Vis d'alimentation G03 - Schnecke G03
- I 02** Coclee 12 file G03 - Auger with clutch 12 rows G03 - Vis d'alimentation 12 éléments G03 - 12-reihiger schnecke G03
- I 03** Coclee 16 file G03 - Auger with clutch 16 rows G03 - Vis d'alimentation 16 éléments G03 - 16-reihiger schnecke G03



Q

**IMPIANTO IDRAULICO
HYDRAULIC SYSTEM
SYSTÈME HYDRAULIQUE
HYDRAULISCHES SYSTEM**











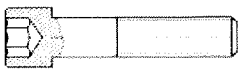







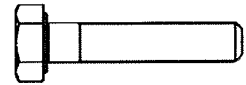
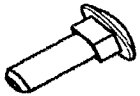



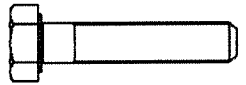



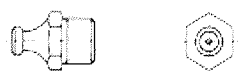
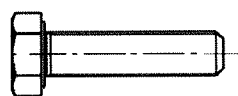

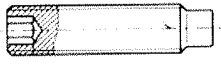

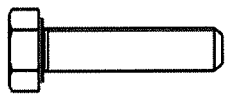



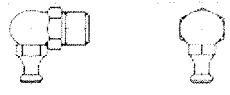
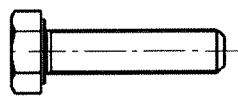

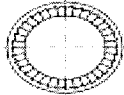













- Q 01** Impianto idraulico - Hydraulic system - Systeme hydraulique - Hydraulisches System

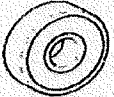
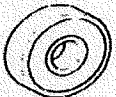

* GH3 = Modello testata pieghevole
** G03 = Modello testata fissa

UNI - ISO

International Organization for Standardization

				
UNI 5931 8.8 ISO 4762	UNI 6592 ISO 7092	UNI 7474 B DIN 985	UNI 5737 8.8 ISO 4014	UNI 9200 ISO 7337
				
UNI 5933 10.9 DIN 7991	UNI 6593 ISO 7093	UNI 7473 A ISO 7040	UNI 5737 10.9 ISO 4014	UNI 5732 ISO 8677/4034
				
UNI 5923 45H ISO 4026	UNI 6604 ISO R773	UNI 1751 ISO 7040	UNI 5738 8.8 ISO 8765	UNI 6873 ISO 8752
				
UNI 5927 45H ISO 4027	RDE UNI8842A ISO 6798A	UNI 7663A ISO 71412A	UNI 5739 8.8 ISO 4017	UNI 5587 ISO 4033
				
UNI 5925 45H ISO 4028	Est. UNI 7435 DIN 471	UNI 7663B 45° ISO 71412B	UNI 5739 10.9 ISO 4017	UNI 5588 ISO 4032
				
UNI 8117 ISO 18480	Int. UNI 7437 DIN 472	UNI 7663C 90° ISO 71412C	UNI 5740 ISO 8676	UNI 5589 ISO 4035
				
CONTACT	UNI9201	DIN 6923	"A" UNI 8833	NILOS 2207 JV
				
6307	30207	6206 2RS	30208	NILOS 6207 JV
				
6207	6205 2RS	6205 2RS	32207	OR 4118
				
6208	6304 2RS	PNA 2042	6004-2RS	OR 3137
				
6209	2207 2RS	6307	61904 2RS	30209

A 01

FORCELLA SX
LEFT FORK
FOURCHE

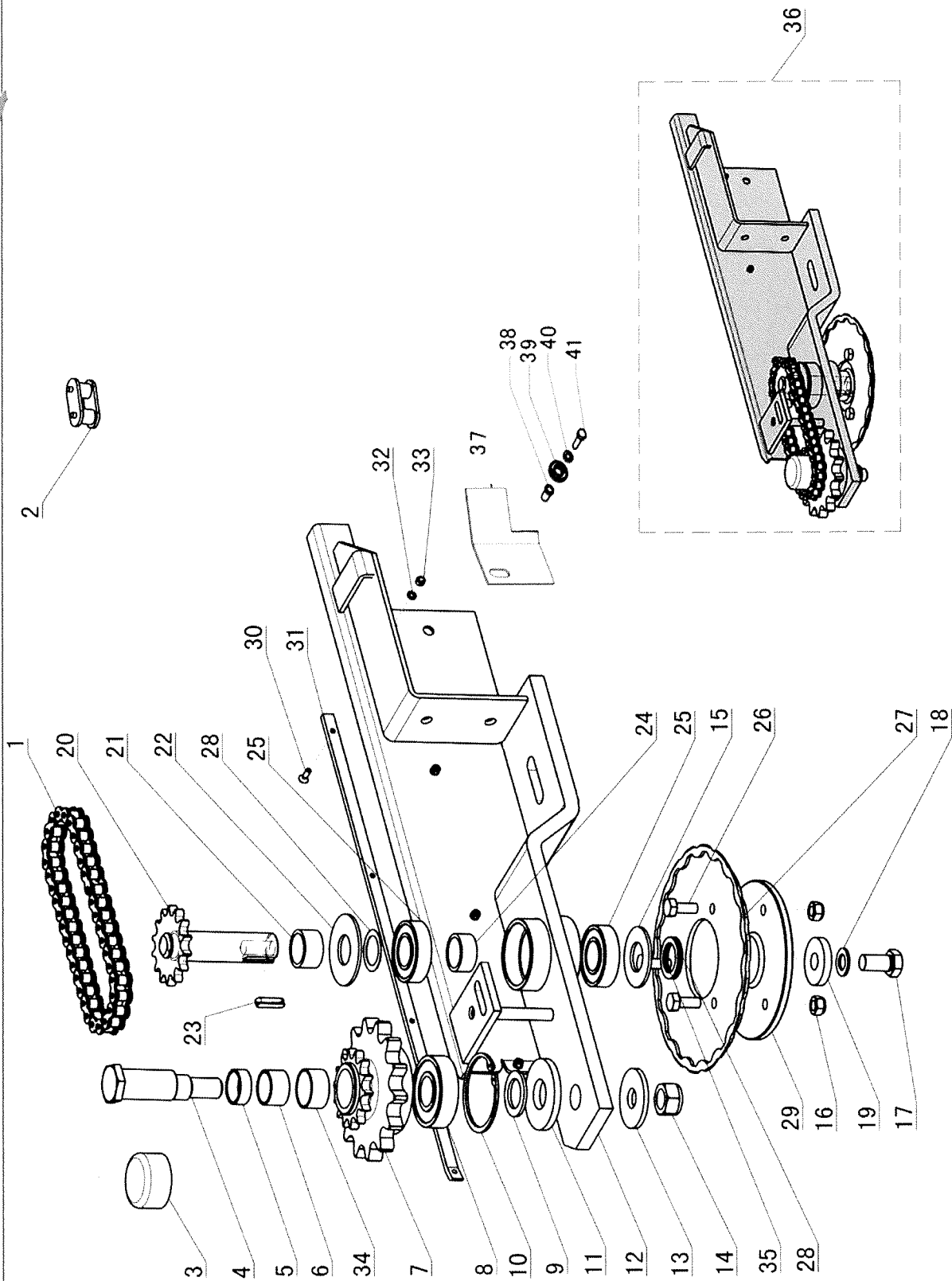

P.	CODICE Code	Qt.	DENOMINAZIONE Description	PREZZO Price	P.	CODICE Code	Qt.	DENOMINAZIONE Description	PREZZO Price
1	03032	1	ASA 50						
2	03122	1							
3	03374	1							
4	13868	1	E36 D30X076 M20X036						
5	03494	1	30 x 35 x 12,5						
6	03495	1	30 x 35 x 20,5						
7	03417	1	1"1/8 Z014						
8	01274	1	06306-2RS						
9	03351	1	46X30-3						
10	00583	1	UNI 7473-75 INT 75						
11	03693	1	71,4X30-8						
12	03386	1	L						
13	01068	1	20X60X50						
14	04864	1	M20 UNI7473						
15	03371	1							
16	04859	4	M10 UNI 7473						
17	00440	1	TE M16X30 UNI 5739						
18	00917	1	RDE M16 UNI 8842						
19	03327	1	17X48X8						
20	03378	1							
21	03353	1	38X31-20						
22	06828	1	72X30,5-3						
23	00603	1	8X7X30 UNI 6604						
24	03354	1	38X31-16,5						
25	01261	1	06206-2RS						
26	00375	4	TE M10X25 UNI 5739						
27	20405	1							
28	01035	6	42X30X0.5						
29	03376	1							
30	00524	4	TS M05X16 UNI 5933						
31	18756	1							
32	00919	4	RDE 05 UNI 8842						
33	00455	4	M5 UNI 5587						
34	03496	1	35X39X2OP10						
35	01031	11	42X30-0.25						
36	03284	1							
37	16286	1							
38	10950	1							
39	05127	1	08X24X02 UNI 6593						
40	00916	1	RDE M08 UNI 8842						
41	00383	1	TE M08X20 UNI 5739						

A 02

FORCELLA DX
RIGHT FORK
FOURCHE

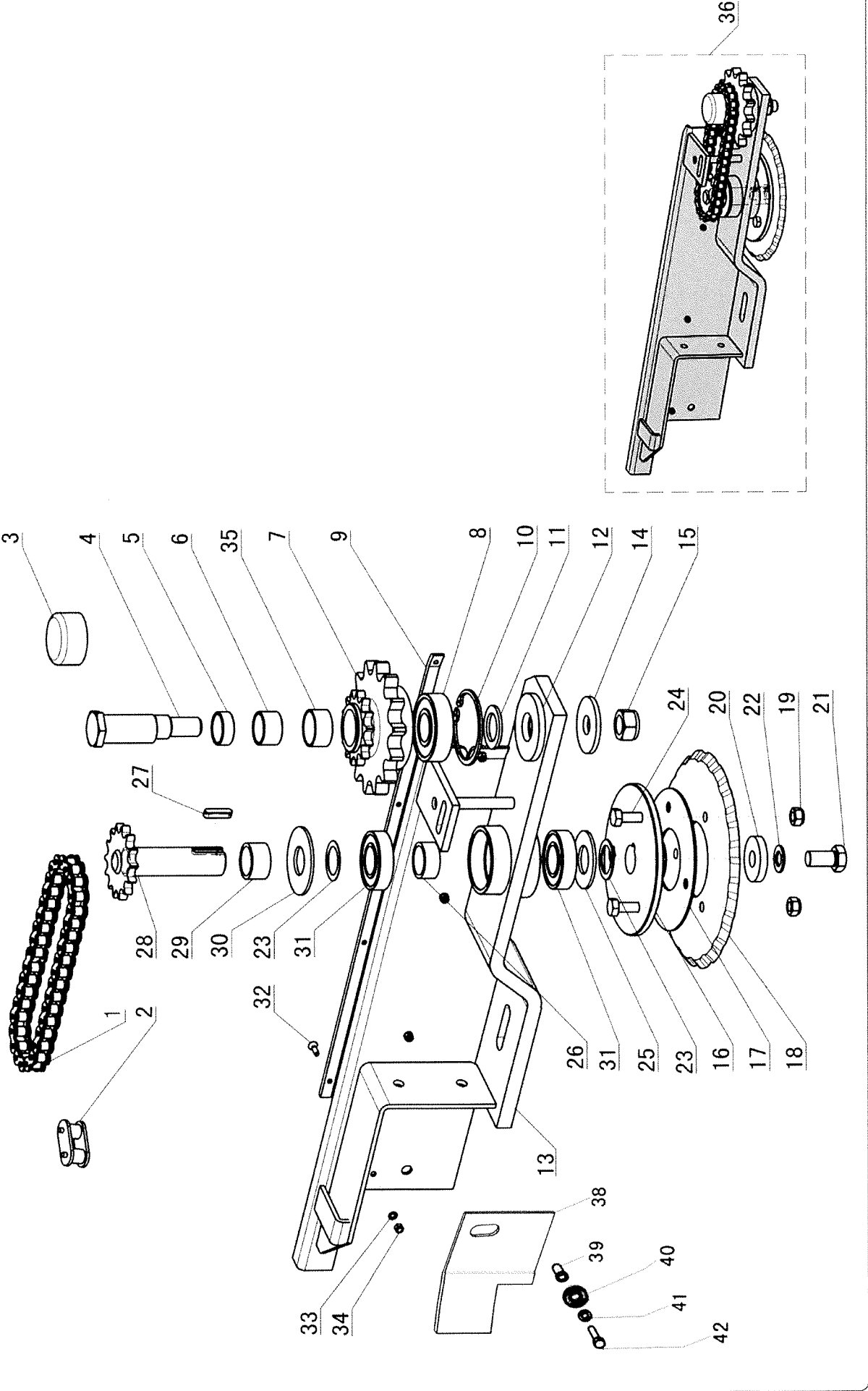
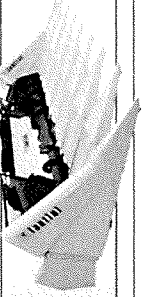

P.	CODICE Code	Qt.	DENOMINAZIONE Description	PREZZO Price	P.	CODICE Code	Qt.	DENOMINAZIONE Description	PREZZO Price
1	03032	1	ASA 50						
2	03122	1	ASA 50						
3	03374	1							
4	13868	1	E36 D30X076 M20X036						
5	03494	1	30 x 35 x 12,5						
6	03495	1	30 x 35 x 20,5						
7	07896	1	1"1/8 Z014						
8	01274	1	06306-2RS						
9	18756	1	12X06-0580						
10	00583	1	UNI 7473-75 INT 75						
11	03351	11	46X30-3						
12	03693	11	71,4X30-8						
13	03385	1	R						
14	01068	1	20X60X5						
15	04864	1	M20 UNI 7473						
16	03376	6							
17	17030	1							
18	20405	1							
19	04859	1	M10 UNI 7473						
20	03327	1	17X48X8						
21	00440	1	TE M16X30 UNI 5739						
22	00917	1	RDE M16 UNI 8842						
23	01035	1	42X30X0,5						
24	00375	1	TE M10X25 UNI 5739						
25	03371	2	DISTANZIALE						
26	03354	3	38X31-16,5						
27	00603	1	8X7X30 UNI 6604-69B						
28	03378	6							
29	03353	1	38X31-20						
30	06828	4	72X30,5X3						
31	01261	1	06206-2RS						
32	00524	4	TS M5X16 UNI 5933						
33	00919	4	RDE M5 UNI 8842						
34	00455	1	M5 UNI 5587						
35	03496	11	35X39X20P10						
36	03283	1							
38	16285	1							
39	10950	1							
40	05127	1	08X24X02 UNI 6593						
41	00916	1	RDE M08 UNI 8842						
42	00383	1	TE M08X20 UNI 5739						

A03

PUNTA CON DENTONI IN GOMMA GH3 - G03
ROW UNIT WITH RUBBER TEETH GH3 - G03
CHAÎNE AV DENTS EN CAOUTCHOUC GH3 - G03

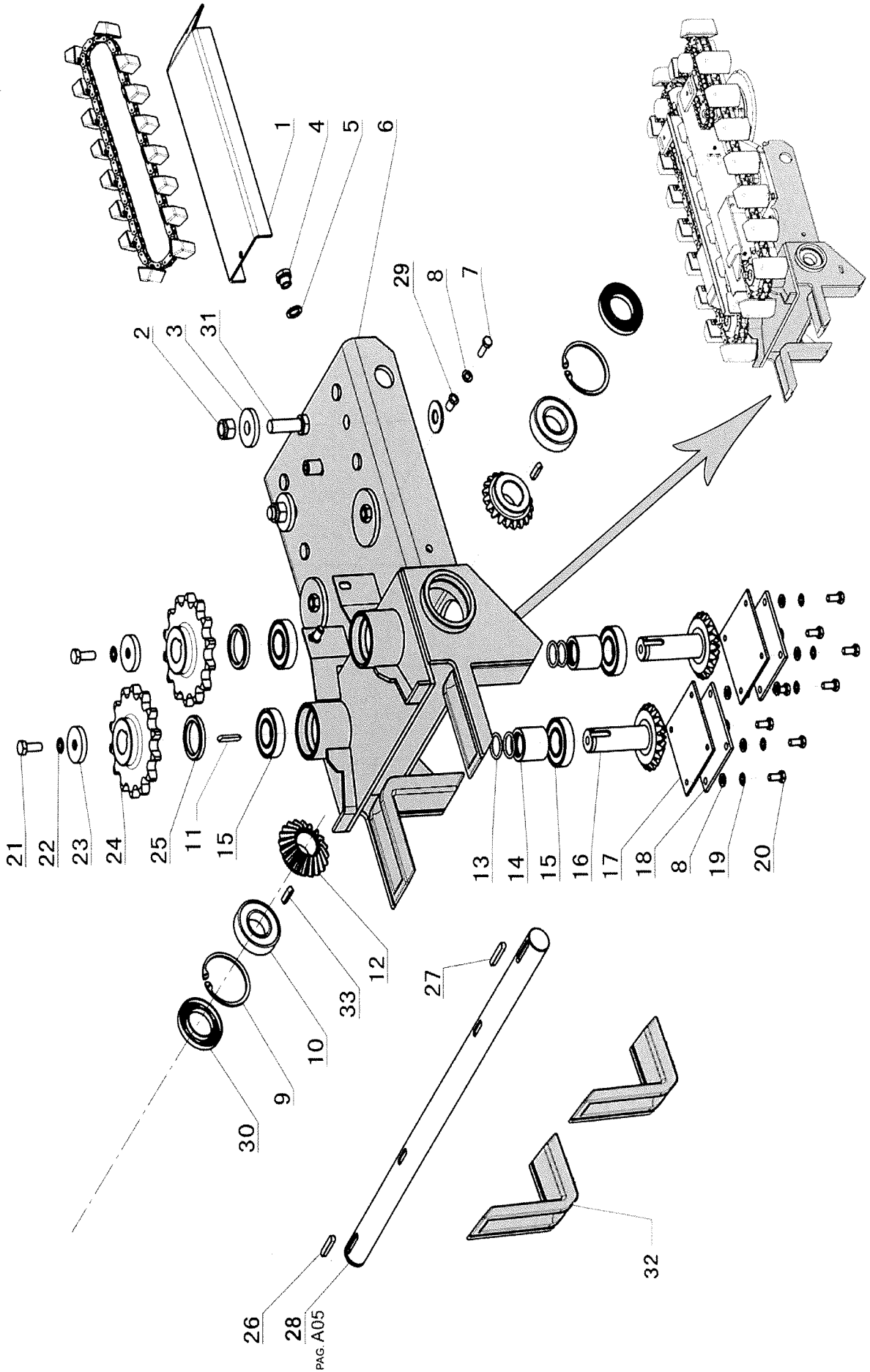

P.	CODICE Code	Qt.	DENOMINAZIONE Description	PREZZO Price	P.	CODICE Code	Qt.	DENOMINAZIONE Description	PREZZO Price
1	03324	1							
2	05115	2	M 16 UNI 7474 B						
3	03327	2	17,0 X 48,0 X 08,0						
4	03925	1	3/8 GAS						
5	12317	1	24 X 16 - 2						
6	21675	1							
7	00377	2	TE M08 X 025 UNI 5739 08,0						
8	00946	10	M08 UNI 6592						
9	00583	2	UNI 7437 - 75 INT. 75						
10	01266	2	6207						
11	00603	2	08 X 07 X 030						
12	18144	2	M04 Z020 D35						
13	01289	4	O.R. 4118 29,75X3,53						
14	18729	2							
15	01261	4	06206-2RS						
16	03400	2	M04 Z020						
17	02516	2	100-04-0100						
18	02510	2	100X5 - 100						
19	00946	8	RDE M08 UNI 8842						
20	00383	8	TE M08X020 UNI 5739 08,8						
21	00438	2	TE M10X030 UNI 5739 10,9						
22	00945	2	M10 UNI 6592						
23	03319	2	13,0X46,0X08,0						
24	03392	2	1" 1/8 Z014						
25	01035	2	42,0X30,0X0,5						
26	00614	1	08x07x040 UNI 6604-69B						
27	00605	2	08x07x045 UNI 6604-69B						
28	0PAG.	*	PAG. A05						
29	10950	2	INSERTO M8 SP08-3,5						
30	18280	2	45x72x10						
31	00441	2	TE M16X055 UNI 5739						
32	17396	2							
33	18227	1	08x06x030						

A03-1

PUNTA PER CINGHIA GH3 - G03
ROW UNIT GH3 - G03
CHAÎNE GH3 - G03

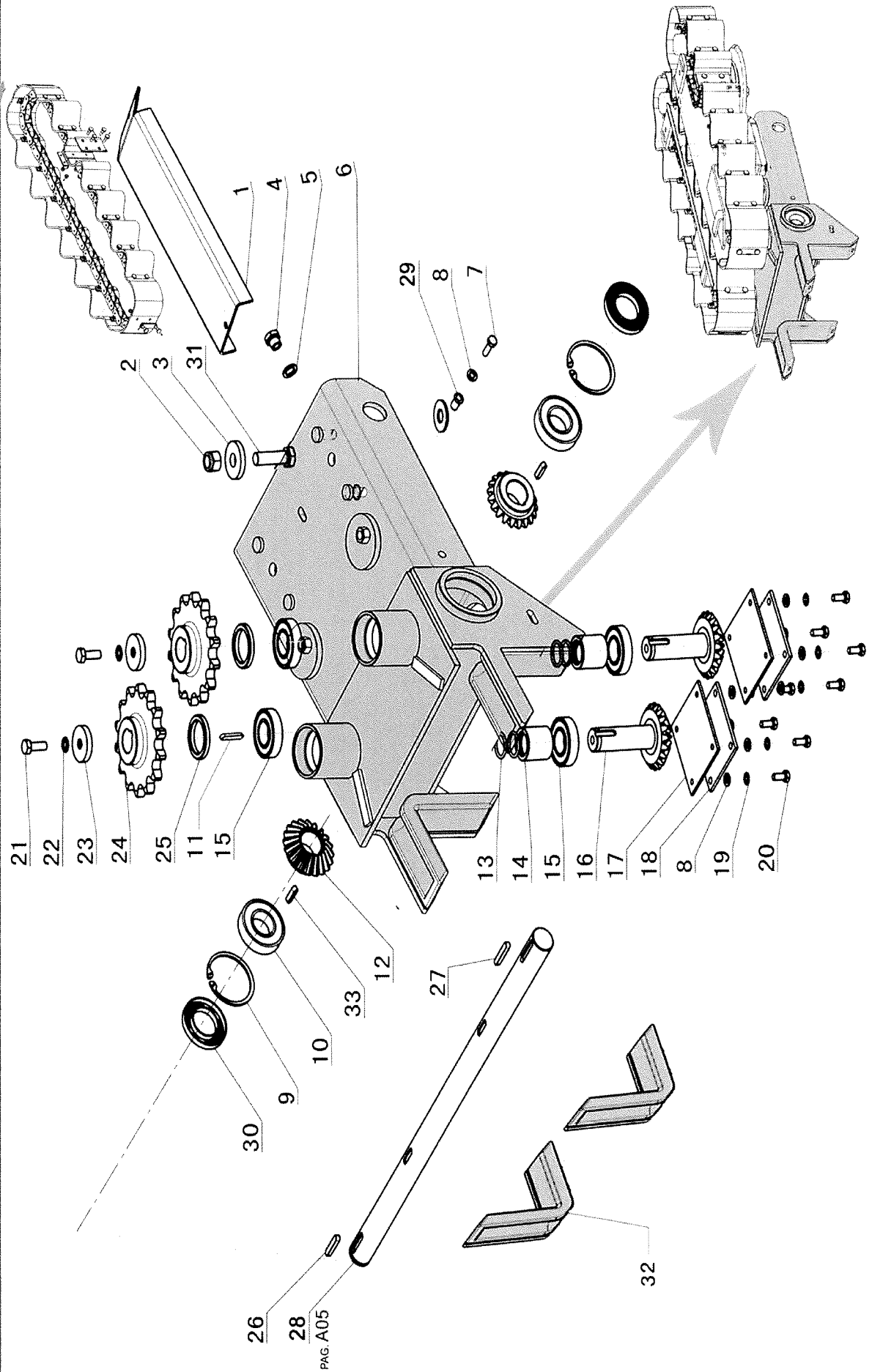

P.	CODICE Code	Qt.	DENOMINAZIONE Description	PREZZO Price	P.	CODICE Code	Qt.	DENOMINAZIONE Description	PREZZO Price
1	03324	1							
2	05115	2	M 16 UNI 7474 B						
3	03327	2	17,0 X 48,0 X 08,0						
4	03925	1	3/8 GAS						
5	12317	1	24 X 16 - 2						
6	23559	1							
7	00377	2	TE M08 X 025 UNI 5739 08,0						
8	00946	10	M08 UNI 6592						
9	00583	2	UNI 7437 - 75 INT. 75						
10	01266	2	6207						
11	00603	2	08 X 07 X 030						
12	18144	2	M04 Z020 D35						
13	01289	4	O.R. 4118 29,75X3,53						
14	18729	2							
15	01261	4	06206-2RS						
16	03400	2	M04 Z020						
17	02516	2	100-04-0100						
18	02510	2	100X5 - 100						
19	00946	8	RDE M08 UNI 8842						
20	00383	8	TE M08X020 UNI 5739 08,8						
21	00438	2	TE M10X030 UNI 5739 10,9						
22	00945	2	M10 UNI 6592						
23	03319	2	13,0X46,0X08,0						
24	03392	2	1" 1/8 Z014						
25	01035	2	42,0X30,0X0,5						
26	00614	1	08x07x040 UNI 6604-69B						
27	00605	2	08x07x045 UNI 6604-69B						
28	OPAG.	*	PAG. A05						
29	10950	2	INSERTO M8 SP08-3,5						
30	18280	2	45x72x10						
31	00441	2	TE M16X055 UNI 5739						
32	17396	2							
33	18227	1	08x06x030						

A 04

CATENA CON DENTONI IN GOMMA
CHAIN WITH RUBBER TEETH
CHAÎNE AV DENTS EN CAOUTCHOUC

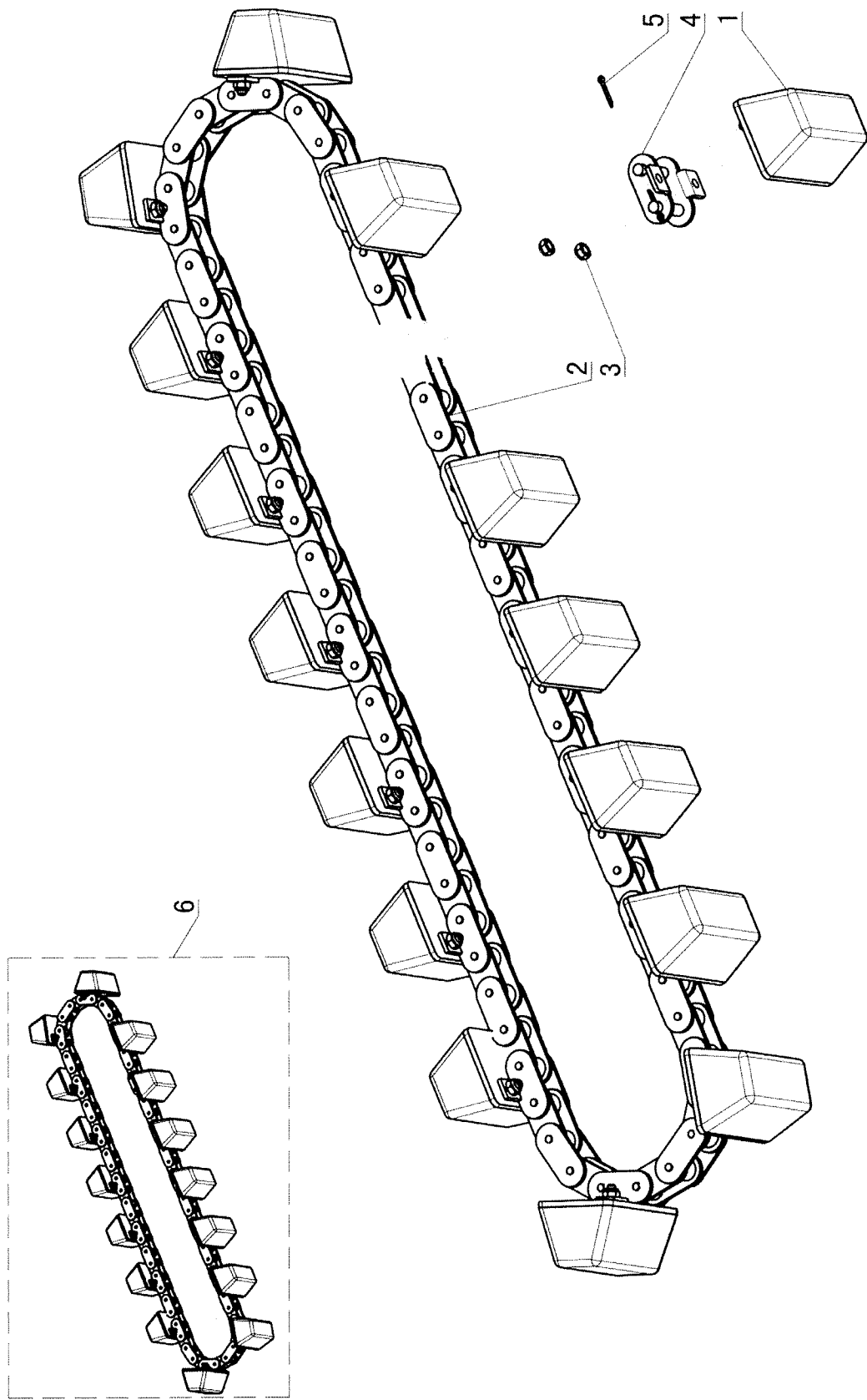

P.	CODICE Code	Qt.	DENOMINAZIONE Description	PREZZO Price	P.	CODICE Code	Qt.	DENOMINAZIONE Description	PREZZO Price
1	18721	16							
2	03743	1	CAE44151						
3	04868	32	M6 UNI 7474						
4	21457	1							
5	22417	2	2.5X016 UNI 1336						
6	19640	1							



A 04-1
CATENA CON GINGHIA
CHAIN
CHAINE

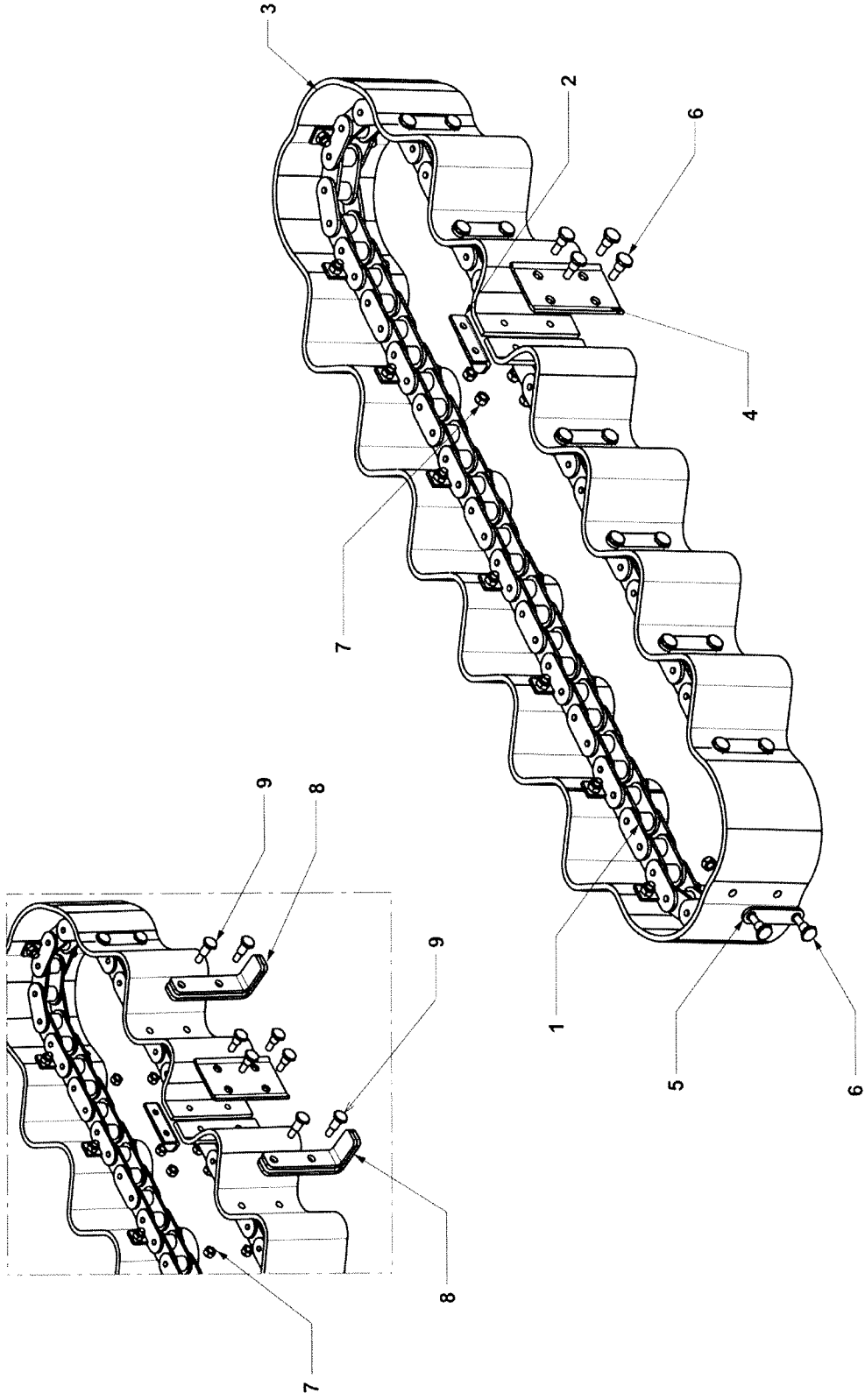

P.	CODICE Code	Qt.	DENOMINAZIONE Description	PREZZO Price	P.	CODICE Code	Qt.	DENOMINAZIONE Description	PREZZO Price
1	03743	*							
2	03744	*							
3	03320	*							
4	03321	*							
5	03322	*							
6	03701	*							
7	04868	*							
8	11441	*							
9	12115	*							

A05

COLLEGAMENTI GRUPPO PUNTE G03
ROW UNITS CONNECTION G03
CONNECTIONS ENTRE RANGS G03

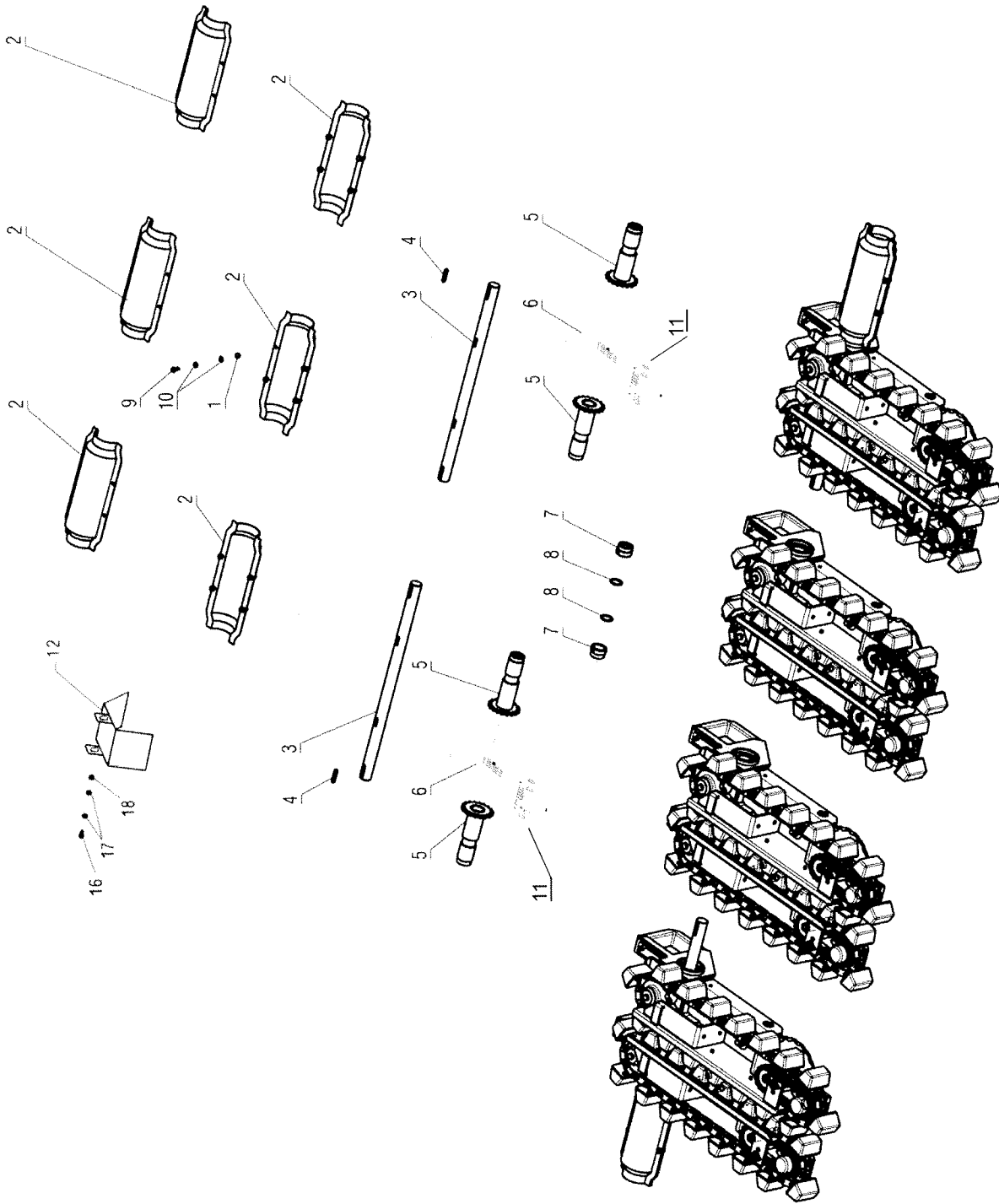

P.	CODICE Code	Qt.	DENOMINAZIONE Description	PREZZO Price	P.	CODICE Code	Qt.	DENOMINAZIONE Description	PREZZO Price
1	04858	4	M8 AUT UNI 7473						
2	27494	*	REG. 50						
2	25541	*	REG. 51						
2	27468	*	REG. 56						
2	27769	*	REG. 60						
2	21947	*	REG. 70						
2	21946	*	REG. 75						
2	21944	*	REG. 76						
2	21943	*	REG. 80						
3	18969	*							
4	00605	*	08X04X45 UNI 6604-69B						
5	19253	*	REG. 45						
5	22952	*	REG. 50 - 55 - 56 - 60						
5	02481	*	REG. 70 - 75 - 80						
6	17402	*							
7	18999	*							
8	01321	*	OR 4137 34,52X3,53						
9	00383	4	TE M8X20 UNI 5739						
10	00946	8	ROSETTA M8 UNI 6592						
11	17435	*							
12	25541	*	REG. 50						
12	27468	*	REG. 55						
16	00384	1	TE M10X30 UNI 5739						
17	20533	2	10X20X03 UNI 6593						
18	04859	1	M10 UNI 7473						

A06

COLLEGAMENTI GRUPPO PUNTE GH3
ROW UNITS CONNECTION GH3
CONNECTIONS ENTRE RANGS GH3

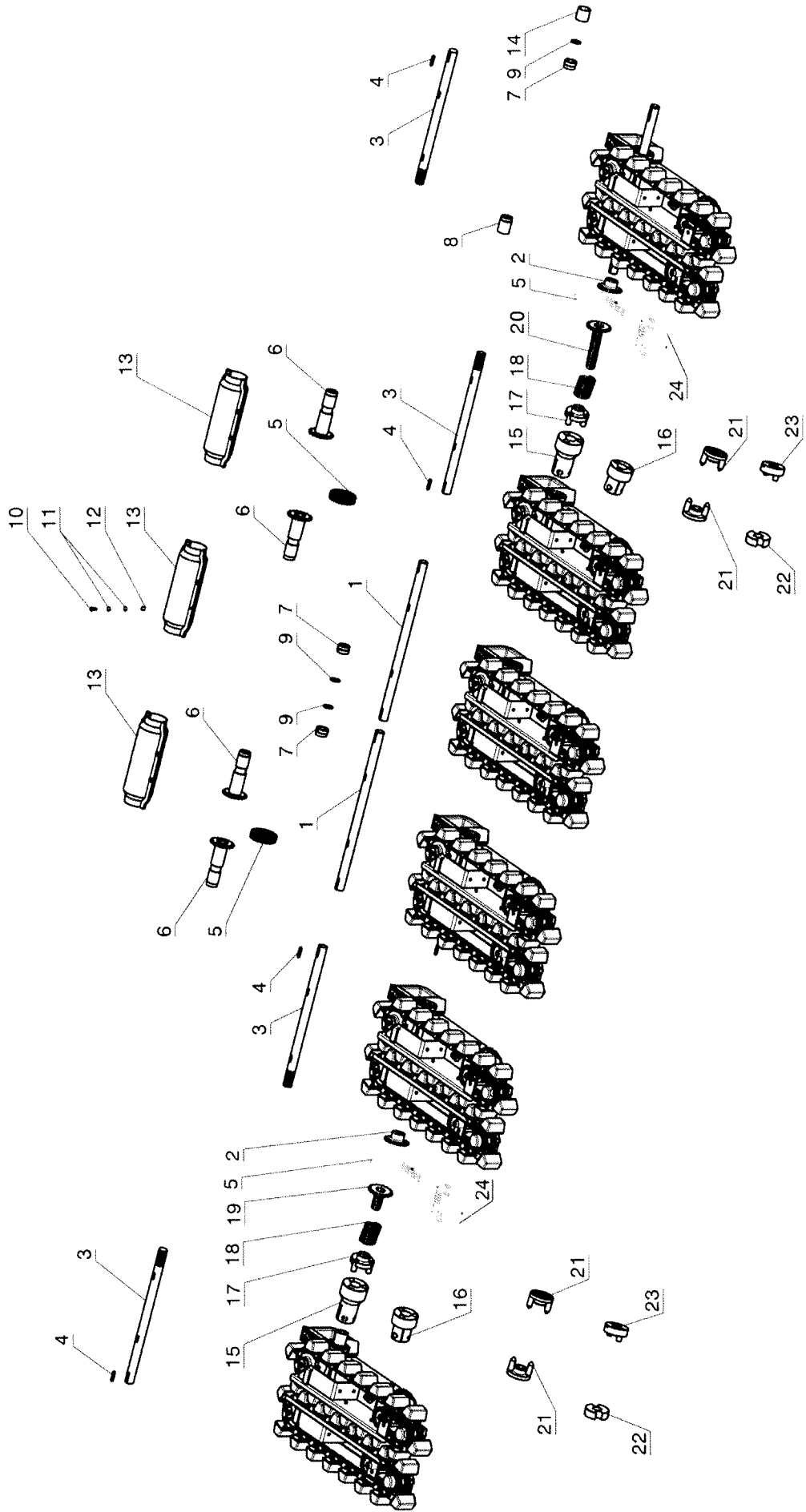

P.	CODICE Code	Qt.	DENOMINAZIONE Description	PREZZO Price	P.	CODICE Code	Qt.	DENOMINAZIONE Description	PREZZO Price
1	18969	*	L=698						
2	13083	2							
3	14457	*	L=581						
3	21814	*	L=647						
4	00605	*	08X07X45						
5	17402	1							
6	02481	2							
7	18999	2	48,3X35-0029						
8	19001	2	48,3X35-0066						
9	01321	2	OR 4137 34,52X3,53						
10	00383	4	TE M08X20 UNI 5739						
11	00946	8	M08 UNI 6592						
12	04858	4	M8 AUT UNI 7473						
13	27494		REG. 50						
13	25541		REG. 51						
13	27468	*	REG. 56						
13	27769		REG. 60						
13	21947	*	REG. 70						
13	21946	*	REG. 75						
13	21944	*	REG. 76						
13	21943		REG. 80						
14	22032	*							
15	20805	2							
16	20799	2							
17	20806	2							
18	10393	2							
19	12362	2							
19	12362	2	R L=87 mm M12						
19	14159	2	R L= 187 mm M12						
19	14157	2	R L=137 mm M12						
20	14160	2	L L= 187 mm M10						
20	14158	2	L L=137 mm M10						
20	11993	2	L L=87 mm M10						
21	18936	4	REG. 60 - 50 - 55 - 56						
22	20429	2	REG 45						
23	20427	2	REG. 45						
24	17435	*							

A07

ALBERO GRUPPO PUNTE GH3
ROW UNITS CONNECTIONS SHAFTS GH3
ARBRE DE CONNECTIONS GH3

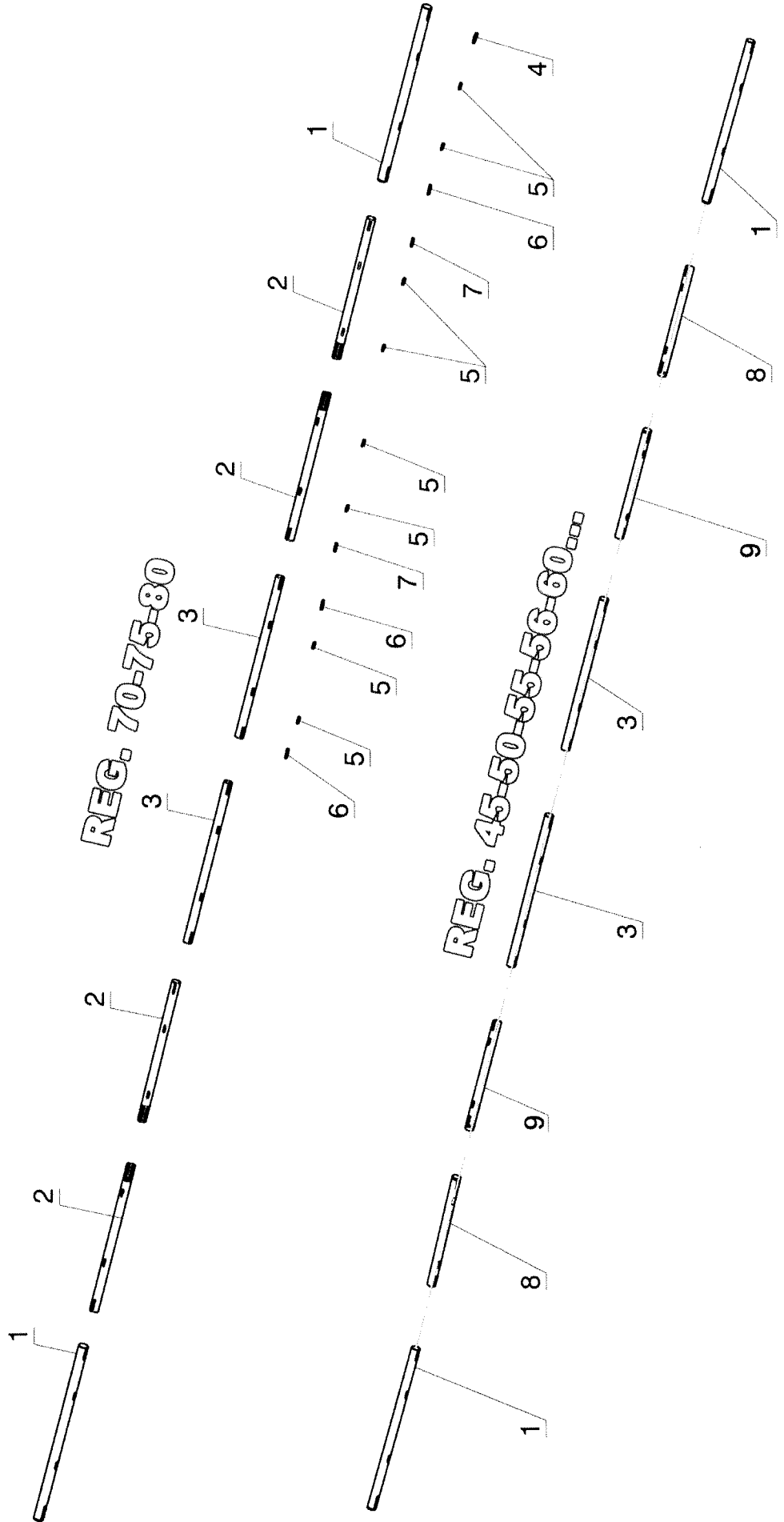

P.	CODICE Code	Qt.	DENOMINAZIONE Description	PREZZO Price	P.	CODICE Code	Qt.	DENOMINAZIONE Description	PREZZO Price
1	19251	*	L=606 REG. 45						
1	18967	*	L=631 REG. 50						
1	18960	*	L=656 REG. 55						
1	20488	*	L=661 REG. 56						
1	19759	*	L=681 REG. 60						
1	18983	*	L=731 REG. 70-75-80						
1	22311	*	L=777 12 FILE REG. 70-75-80						
1	20749	*	L=838.5 REG. 91,5						
2	22309	*	L= 531 6X96,5						
2	21813	*	L= 614,5 8F						
2	21814	*	L= 647 6F						
3	19249	*	C L= 448 REG. 45						
3	18993	*	C L= 498 REG. 50						
3	18962	*	C L= 548 REG. 55						
3	20487	*	C L= 558 REG. 56						
3	19760	*	C L= 598 REG. 60						
3	18969	*	C L= 698 REG. 70-75-80						
3	20748	*	C L= 913 REG. 91,5						
4	01072	*	10X07X047						
5	00603	*	08X07X030 UNI 6604-69B						
6	00605	*	08X07X045 UNI 6604-69B						
7	00614	*	08X07X040 UNI 6604-69B						
8	18984	*	L=595 8X75						
8	18970	*	L=598 8X70						
8	18989	*	L=617 8X80						
8	18994	*	L=631 6X70						
8	22017	*	L=658 8X60						
8	18971	*	L=757 6X75						
8	22311	*	L=777 12X70						
8	22307	*	L=808 6X96,5						
9	20383	*	L= 723 10X75						
9	18992	*	L=489 REG. 50						
9	18961	*	L=548 REG. 55						
9	22019	*	L=619 8X60						
9	18973	*	L=720 6X75						
9	18987	*	L=772 6X80						
9	18968	*	L=798 REG. 70						
9	18986	*	L=850 8X75						
9	18990	*	L=879 8X80						

B01

**LEVE PER CHIUSURA TELAIO GH3
FRAME FOLDING LEVERS GH3
LEVIER POUR FERMETURE CHASSIS GH3**

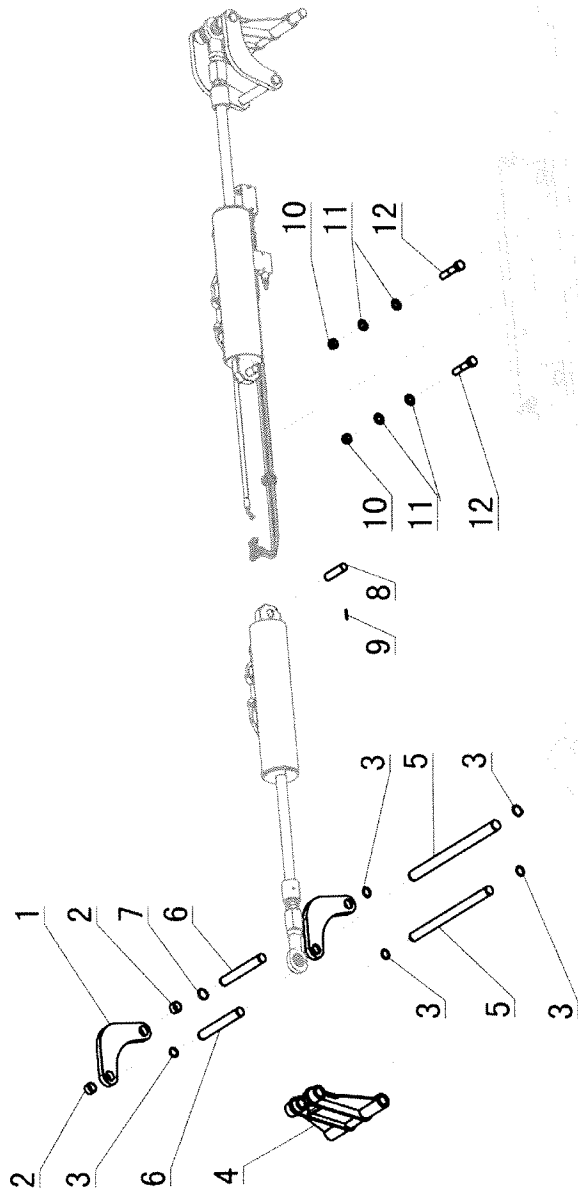

P.	CODICE Code	Qt.	DENOMINAZIONE Description	PREZZO Price	P.	CODICE Code	Qt.	DENOMINAZIONE Description	PREZZO Price
1	10949	4							
2	07602	8	30X34X20P10						
3	00581	12	UNI 7435-75 EST 30						
4	12509	2							
5	12518	2	30X0427						
6	12519	4	30X0220						
7	00590	4	UNI 7435-75 EST 35						
8	10975	2	PERNO FISS. CILINDRO ZINCATO						
9	01004	4	SPINA ELASTICA 05X050 IO 8750						
10	04864	2	M20 AUT UNI 7473						
11	00948	4	M20 UNI 6592						
12	00424	2	TE M20X80 UNI 5737						

B 02

**LEVE PER CHIUSURA TELAIO 12 FILE GH3
12-ROWS FRAME FOLDING LEVERS GH3
12 RANGS LEVIER POUR FERMETURE CHASSIS GH3**

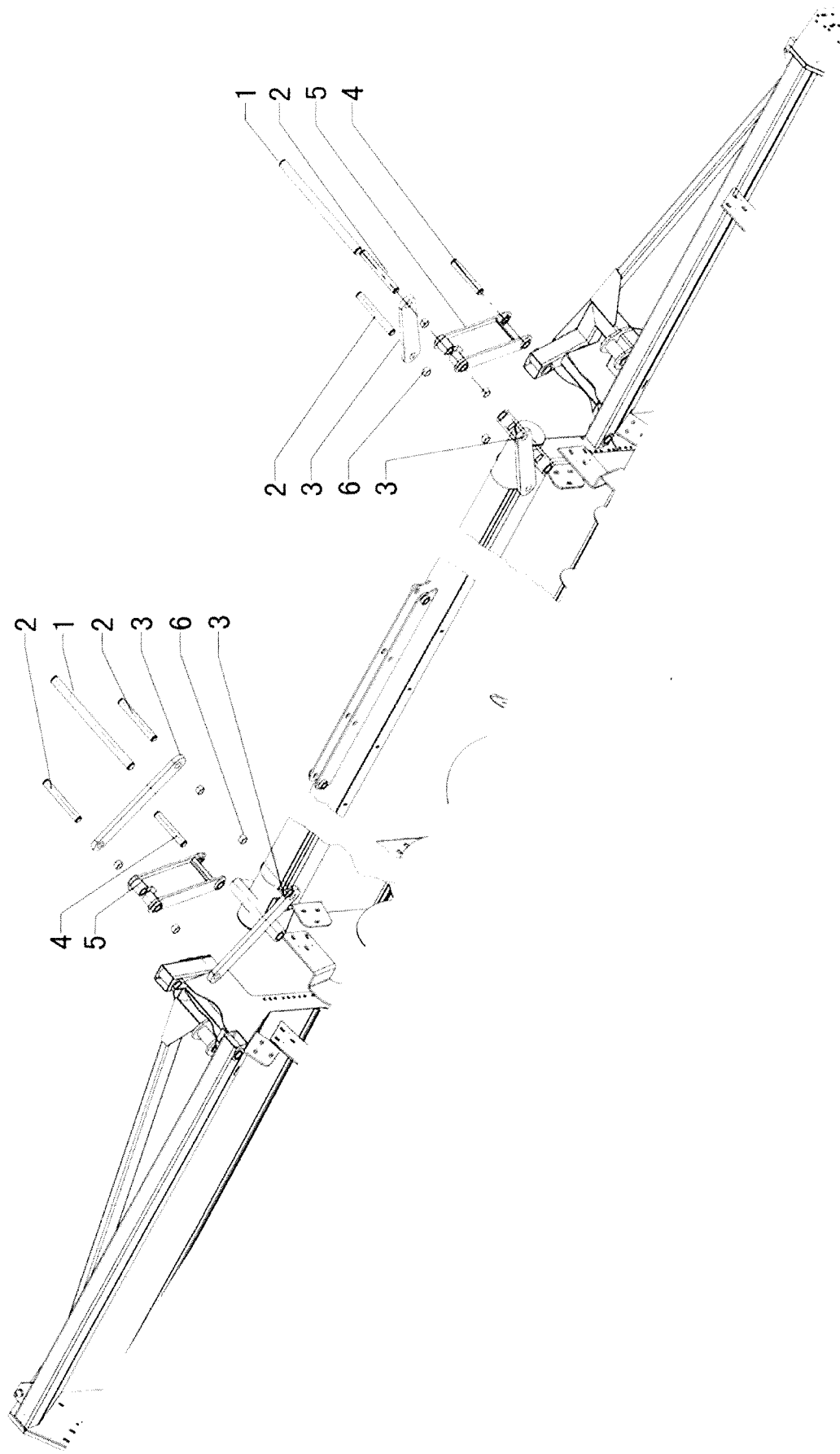

P.	CODICE Code	Qt.	DENOMINAZIONE Description	PREZZO Price	P.	CODICE Code	Qt.	DENOMINAZIONE Description	PREZZO Price
1	19069	2							
2	12519	4							
3	21217	4							
4	19070	2							
5	21219	2							
6	07602	8	PAP 30X34X20P10						

C01

COFANATURA LATERALE DX G03
RIGHT SIDE BONNET G03
CAPOT LATERAL DROITE G03

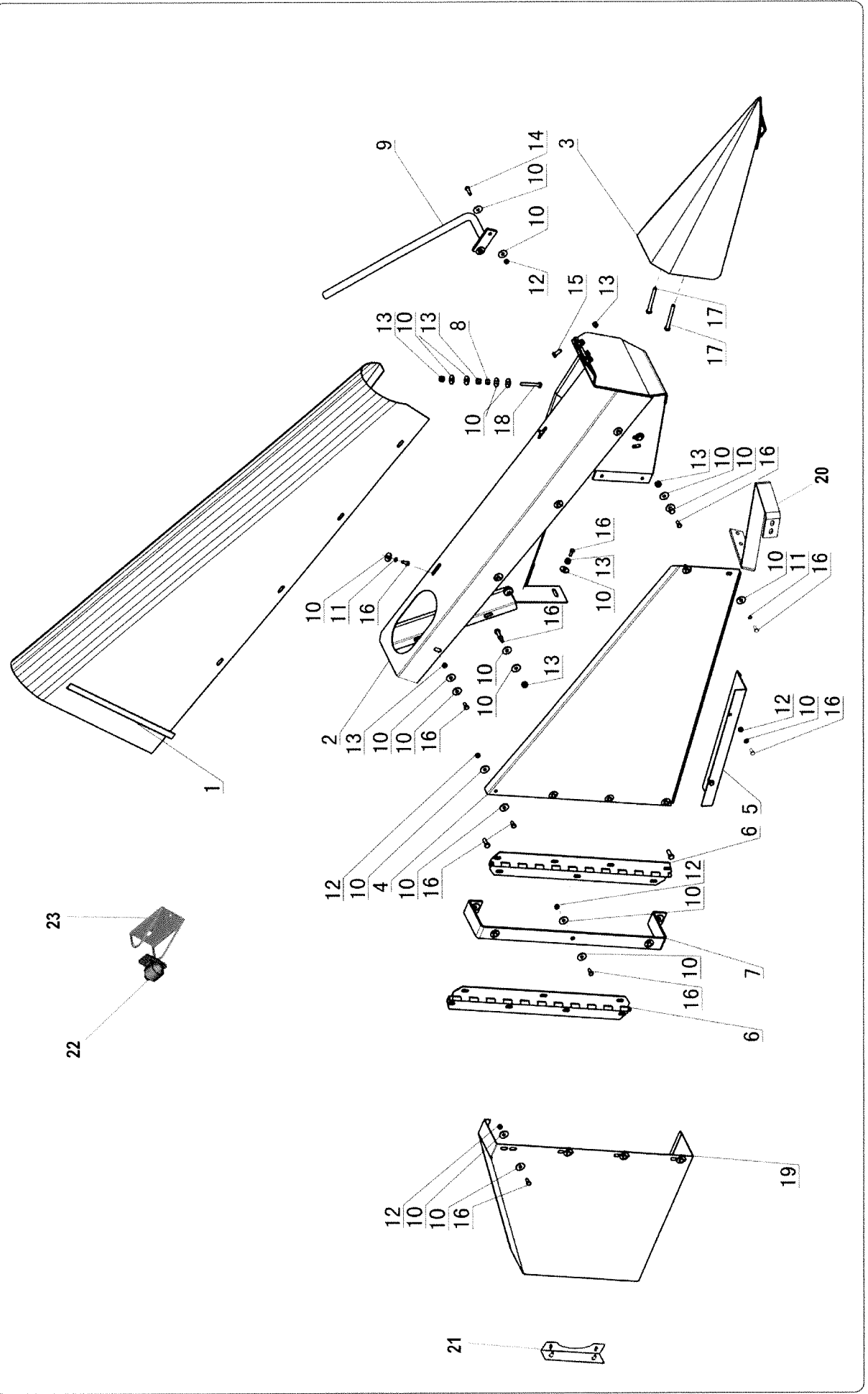
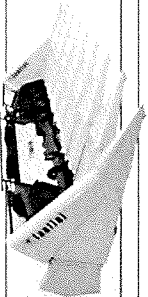

P.	CODICE Code	Qt.	DENOMINAZIONE Description	PREZZO Price	P.	CODICE Code	Qt.	DENOMINAZIONE Description	PREZZO Price
1	21613	1	R						
2	02389	1	R						
3	02734	1	R						
4	22178	1	R						
5	02848	1							
6	05195	1							
7	05467	1							
8	00471	1	M10 UNI 5587						
9	02879	1							
10	00928	12	10X30X03 UNI 6593						
11	00916	4	R.D.E. M08 UNI 8842						
12	04858	13	M8 UNI 7473 AUTOB						
13	04859	10	M10 UNI 7473 AUTOB						
14	00379	2	TE M08X030 UNI 5739						
15	00375	4	TE M10X025 UNI 5739						
16	00383	16	TE M08X020 UNI 5739						
17	00413	1	TE M10X70 UNI 5739						
18	13174	1	TE M10X80						
19	17081	1	R L= 530mm						
19	20110	1	R L= 560mm						
20	23970	1							
21	22972	1	R						
21	18297	1	Y						
22	18017	1							
23	18423	1							

G02

COFANATURA LATERALE SX G03
LEFT SIDE BONNET G03
CAPOT LATERAL GAUCHE G03

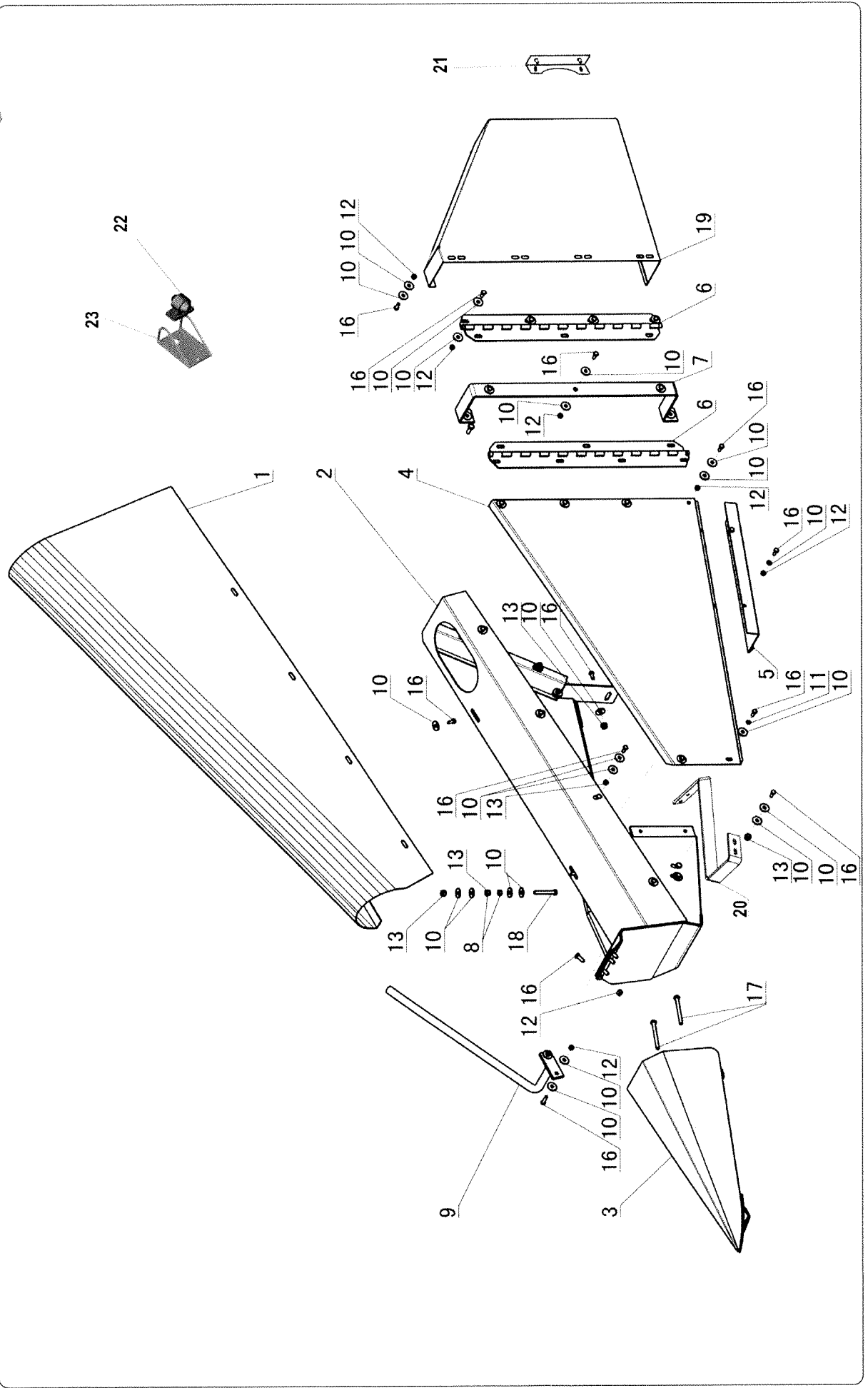
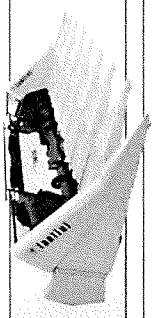

P.	CODICE Code	Qt.	DENOMINAZIONE Description	PREZZO Price	P.	CODICE Code	Qt.	DENOMINAZIONE Description	PREZZO Price
1	21633	1	L						
2	02391	1	L						
3	02735	1	L						
4	22179	1	L						
5	02848	1							
6	05195	1							
7	05467	1							
8	00471	2	M10 UNI 5587						
9	02878	1							
10	00928	12	10X30X03 UNI 6593						
11	00916	4	R.D.E. M08 UNI 8842						
12	04858	13	M8 UNI 7473 AUTOB						
13	04859	10	M10 UNI 7473 AUTOB						
14	00379	2	TE M08X030 UNI 5739						
15	00375	4	TE M10X025 UNI 5739						
16	00383	16	TE M08X020 UNI 5739						
17	00413	1	TE M10X70 UNI 5739						
18	13174	1	TE M10X80						
19	17080	1	L L=530mm						
19	20111	1	L L=560mm						
20	23971	1							
21	22972	1	R						
21	18297	1	Y						
22	18017	1							
23	18423	1							

C03

COFANATURA LATERALE DX GH3
RIGHT SIDE BONNET GH3
CAPOT LATERAL DROITE GH3

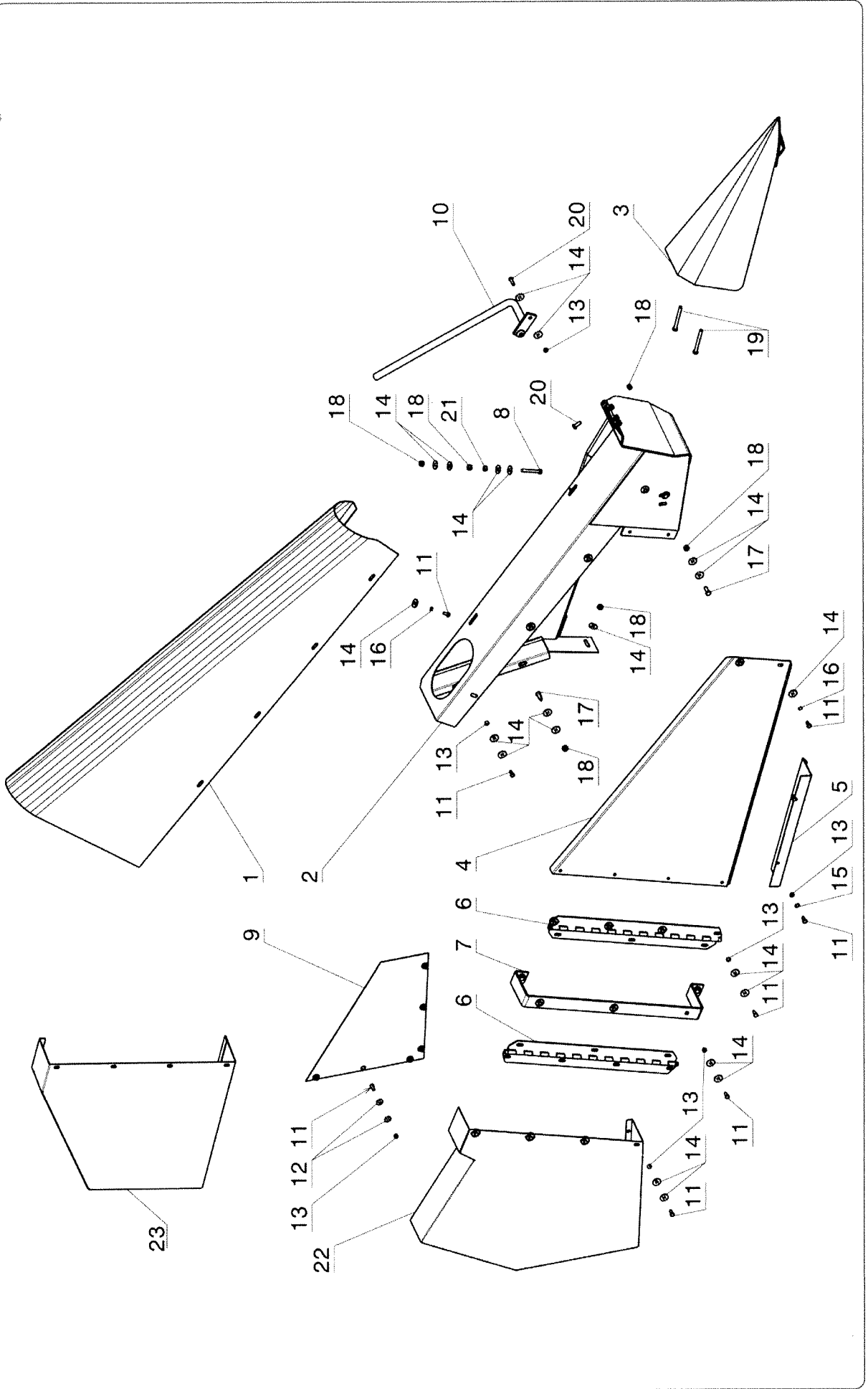

P.	CODICE Code	Qt.	DENOMINAZIONE Description	PREZZO Price	P.	CODICE Code	Qt.	DENOMINAZIONE Description	PREZZO Price
1	02712	1	R GH3						
1	22443	1	R GH3 12 FILE						
2	02389	1	R						
3	02734	1	R						
4	22178	1	R						
5	02848	2							
6	05195	1							
7	05467	1							
8	13174	1	TE M10X080 UNI 5739						
9	23236	1							
10	05879	1							
11	00383	16	TE M08X20 UNI5739						
12	05127	34	08X04X02 UNI 6593						
13	04858	13	M08 AUT UNI 7473						
14	00928	12	10X30X03 UNI 6593						
15	00946	*	M8 UNI 6592						
16	00916	4	RDE M08 UNI 8842						
17	00384	3	TE M10X30 UNI 5739						
18	04859	10	M10AUT UNI 7473						
19	00413	1	TE M10X70 UNI 5739						
20	00379	2	TE M08X30 UNI 5739						
21	00471	*	M10 UNI 5587						
22	17961	1	R GH3						
23	22455	1	R GH3 12 FILE						

C04

COFANATURA LATERALE SX GH3
LEFT SIDE BONNET GH3
CAPOT LATERAL GAUCHE GH3

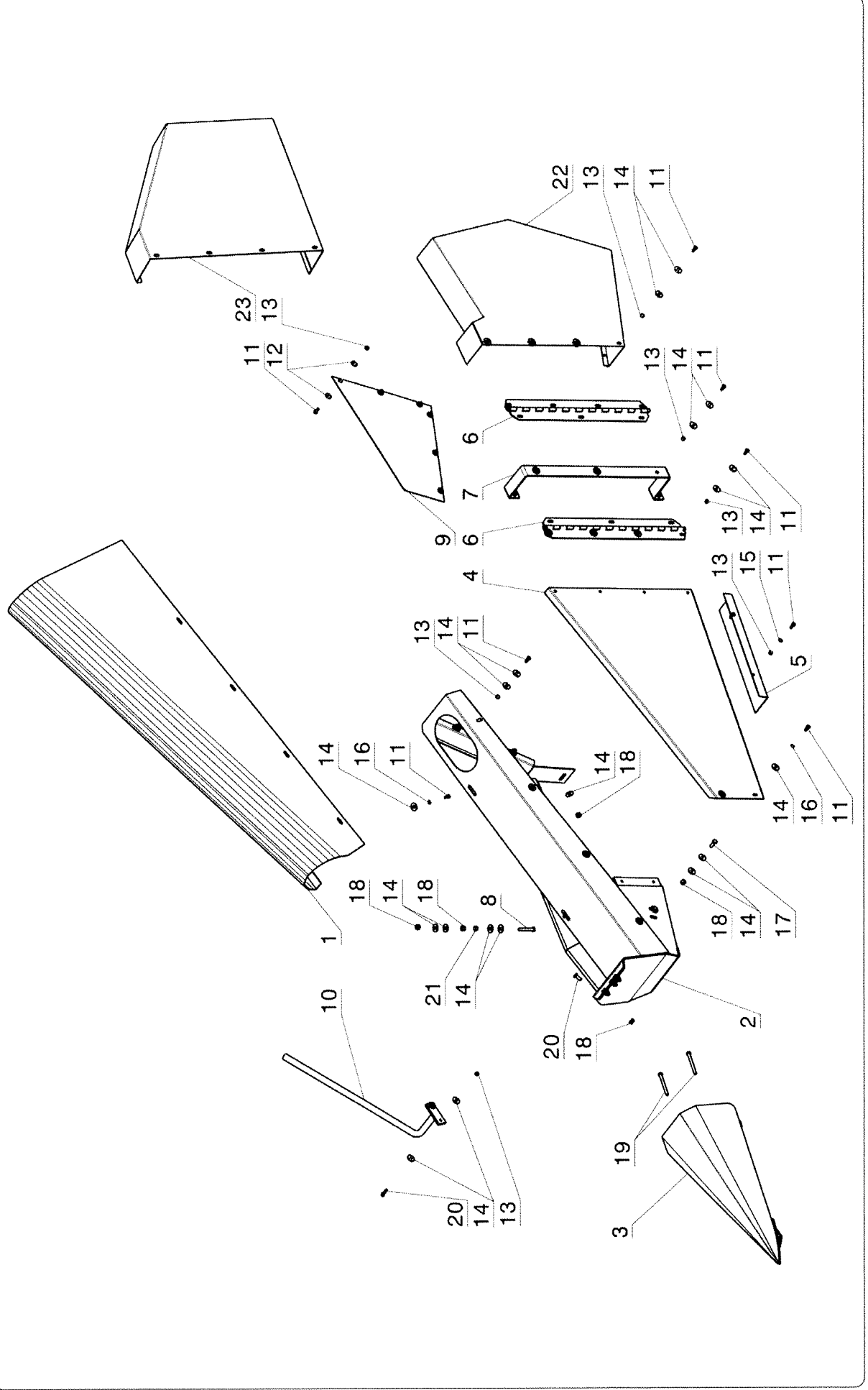

P.	CODICE Code	Qt.	DENOMINAZIONE Description	PREZZO Price	P.	CODICE Code	Qt.	DENOMINAZIONE Description	PREZZO Price
1	02713	1	L GH3						
1	22451	1	L GH3 12 FILE						
2	02391	1	L						
3	02735	1	L						
4	22179	1	L						
5	02848	1							
6	05195	2							
7	05467	1							
8	13174	*	TE M10X080 UNI 5739						
9	23236	1							
10	02878	1							
11	00383	1	TE M08X20 UNI5739						
12	05127	16	08X04X02 UNI 6593						
13	04858	34	M08 AUT UNI 7473						
14	00928	13	10X30X03 UNI 6593						
15	00946	12	M8 UNI 6592						
16	00916	*	RDE M08 UNI 8842						
17	00384	4	TE M10X30 UNI 5739						
18	04859	3	M10AUT UNI 7473						
19	00404	10	TE M10X70						
20	00379	1	TE M08X30 UNI 5739						
21	00471	2	M10 UNI 5587						
22	17960	1	L GH3						
23	22457	1	L GH3 12 FILE						

C 05

COFANATURA CENTRALE G03
CENTRAL BONNETS G03
CAPOT CENTRAL G03

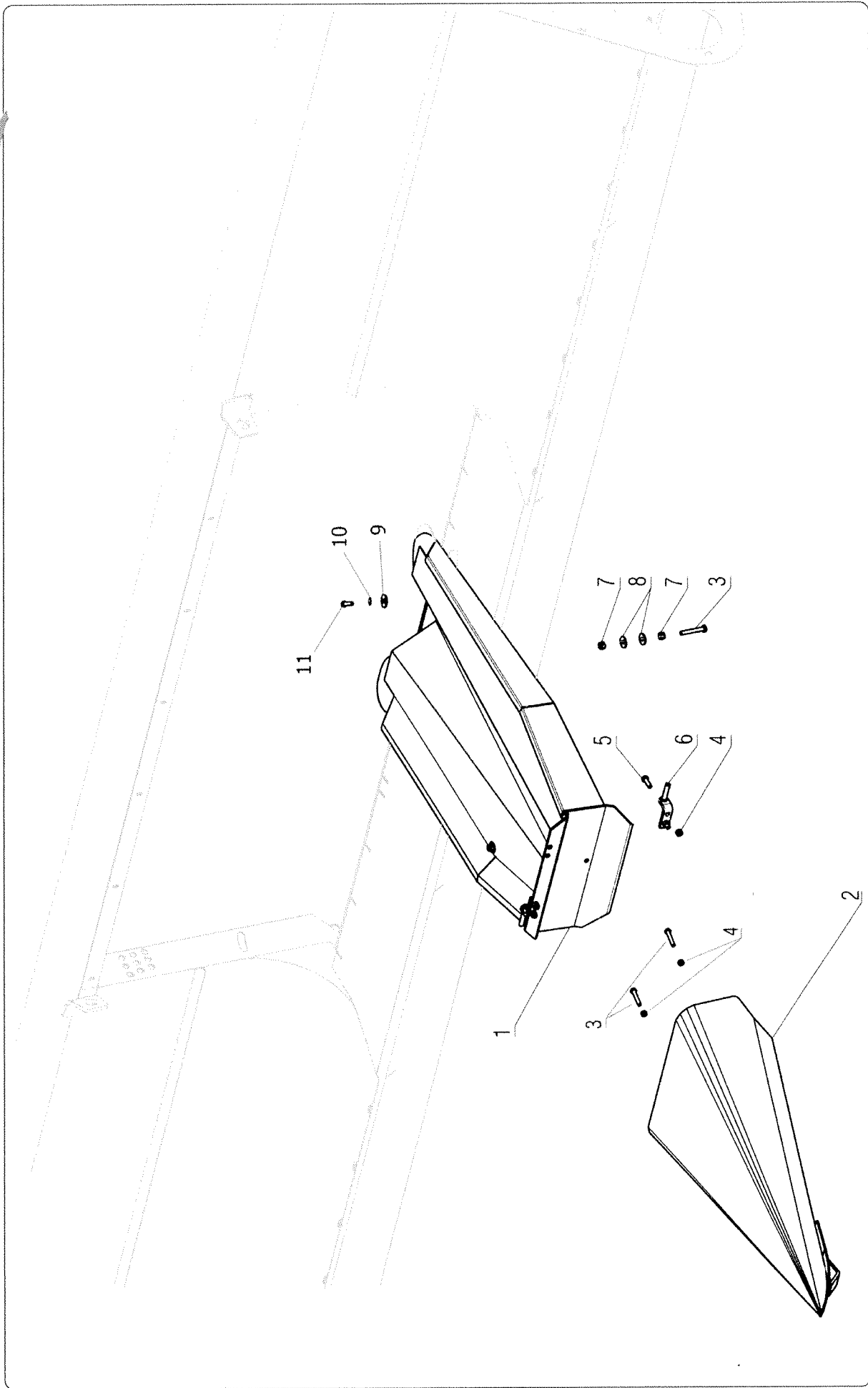

P.	CODICE Code	Qt.	DENOMINAZIONE Description	PREZZO Price	P.	CODICE Code	Qt.	DENOMINAZIONE Description	PREZZO Price
1	02338	*	C REG. 45		4				
1	02341	*	C REG. 50		3				
1	02344	*	C REG. 55		5				
1	20493	*	C REG. 56		0				
1	02347	*	C REG. 60		1				
1	16698	*	C REG. 65						
1	02350	*	C REG. 70						
1	02353	*	C REG. 75						
1	02356	*	C REG. 80						
1	17696	*	C REG. 90						
1	20745	*	C REG. 91,5						
1	17480	*	C REG. 96,5						
2	02752	*	REG. 45						
2	02754	*	REG. 50						
2	02756	*	REG. 55						
2	02758	*	REG. 60						
2	02761	*	REG. 65						
2	02763	*	REG. 70						
2	02765	*	REG. 75						
2	02766	*	REG. 80						
2	17694	*	REG. 90						
2	20747	*	REG. 91,5						
2	17486	*	REG. 96,5						
3	00413	*	TE M10X70 UNI 5739						
4	00471	*	M 10 UNI 5587						
5	00375	*	TE M10X25 UNI 5739						
6	03692	*							
7	04859	*	M10 AUT UNI 7473						
8	00928	*	10X24X02 UNI 6593						
9	05127	1	08X24X02 UNI 6593						
10	00916	1	RDE M08 UNI 8842						
11	00377	1	TE M08X25 UNI 5739						



COFANATURA CENTRALE GH3
CENTRAL BONNETS GH3
CAPOT CENTRAL GH3

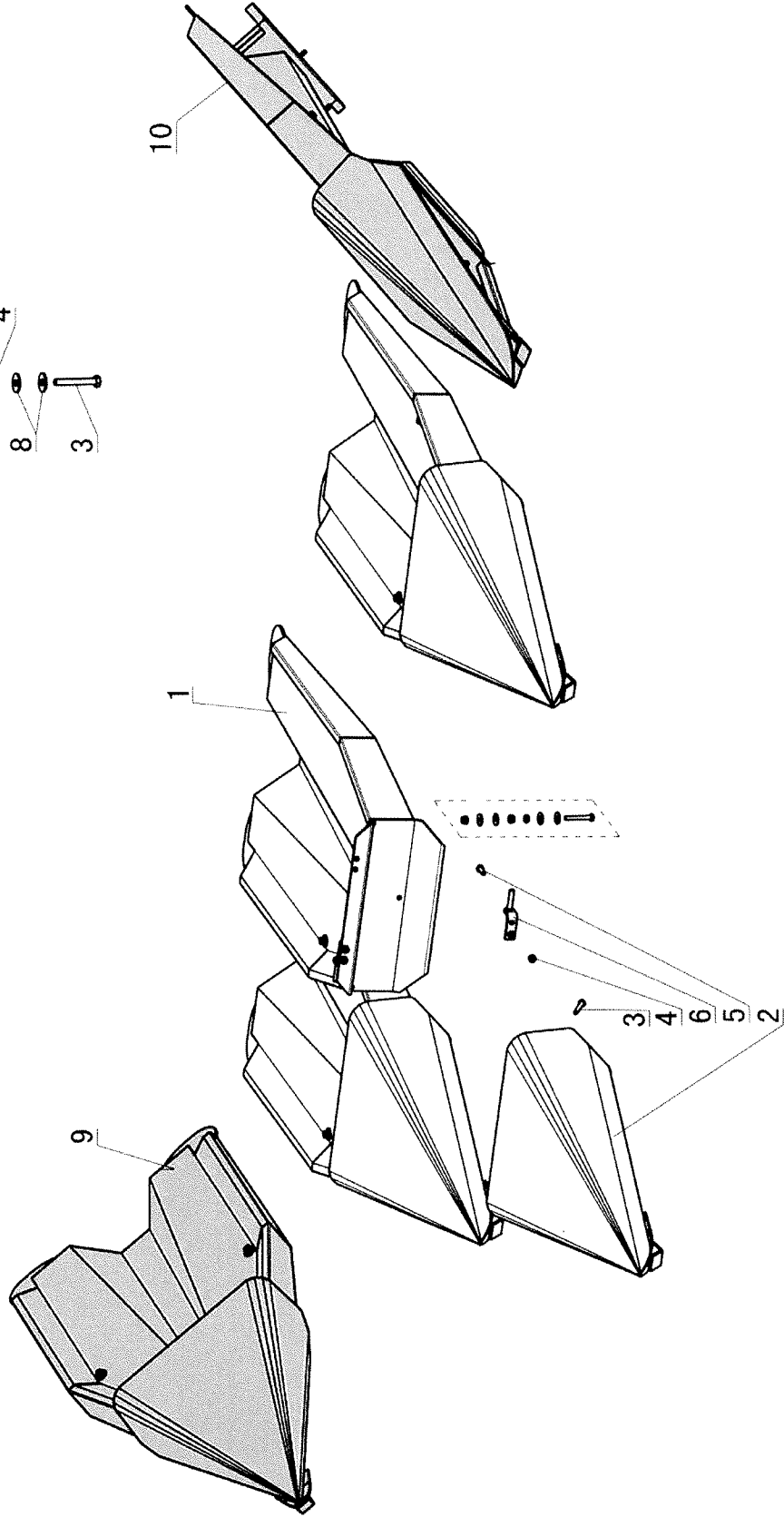
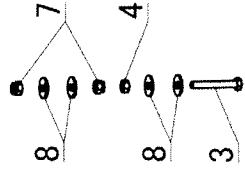

P.	CODICE Code	Qt.	DENOMINAZIONE Description	PREZZO Price	P.	CODICE Code	Qt.	DENOMINAZIONE Description	PREZZO Price
1	02338	*	C REG. 45		4				
1	02341	*	C REG. 50		3				
1	02344	*	C REG. 55		5				
1	20493	*	C REG. 58		0				
1	02347	*	C REG. 60						
1	16698	*	C REG. 65						
1	02350	*	C REG. 70						
1	02353	*	C REG. 75						
1	02356	*	C REG. 80						
1	17696	*	C REG. 90						
1	20745	*	C REG. 91,5						
1	17480	*	C REG. 96,5						
2	02752	*	REG. 45						
2	02754	*	REG. 50						
2	02756	*	REG. 55						
2	02758	*	REG. 60						
2	02761	*	REG. 65						
2	02763	*	REG. 70						
2	02765	*	REG. 75						
2	02766	*	REG. 80						
2	17694	*	REG. 90						
2	20747	*	REG. 91,5						
2	17486	*	REG. 96,5						
3	00413	*	TE M10X70 UNI 5739						
4	00471	*	M 10 UNI 5587						
5	00375	*	TE M10X25 UNI 5739						
6	03692	*							
7	04859	*	M10 AUT UNI 7473						
8	00928	*	10X24X02 UNI 6593						
9	22484	*	R REG. 45						
9	13314	*	R REG. 50						
9	22561	*	R REG. 55						
9	22563	*	R REG. 56						
9	17555	*	R REG. 60						
9	14905	*	R REG. 70						
9	13504	*	R REG. 75						
9	17976	*	R REG. 80						
9	17482	*	R REG. 96,5						
10	22485	*	L REG. 45						
10	13316	*	L REG. 50						
10	22562	*	L REG. 55						
10	22564	*	L REG. 56						
10	17554	*	L REG. 60						
10	14906	*	L REG. 70						
10	13505	*	L REG. 75						
10	17978	*	L REG. 80						
10	17484	*	L REG. 96,5						

C07

**RETI GH3
NET GH3
GRIL DE PROTECTION GH3**

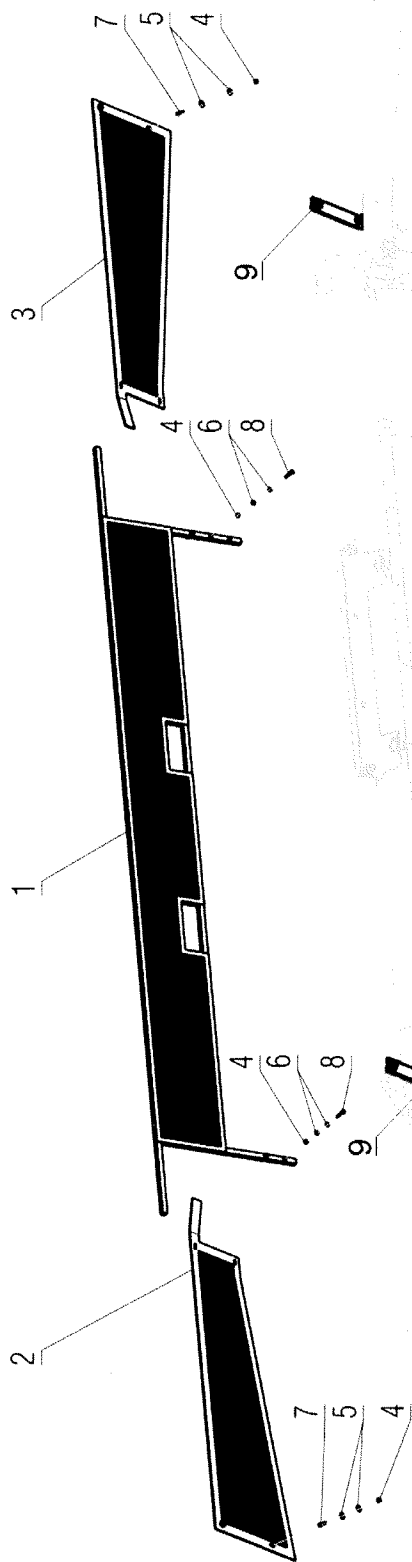
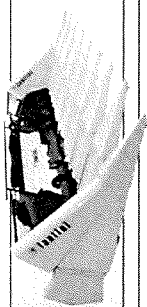

P.	CODICE Code	Qt.	DENOMINAZIONE Description	PREZZO Price	P.	CODICE Code	Qt.	DENOMINAZIONE Description	PREZZO Price
1	16828	1	C 12X45 - 6X96,5 - 8X60 L= 3610						
1	21013	1	C 12X55						
1	22541	1	C 12X70						
1	15218	1	C 6 FILE						
1	15267	1	C 8 FILE						
2	15263	1	R 06X75						
2	17972	1	R 06X80						
2	17460	1	R 06X96,5						
2	15216	1	R 08X50						
2	17588	1	R 08X60						
2	22152	1	R 08X70						
2	15268	1	R 08X75						
2	21615	1	R 08X80						
2	17129	1	R 10X50						
2	17610	1	R 10X60						
2	16830	1	R 12X45						
2	21015	1	R 12X55						
2	22539	1	R 12X70						
3	15264	1	L 06X75						
3	17970	1	L 06X80						
3	17462	1	L 06X96,5						
3	15217	1	L 08X50						
3	17590	1	L 08X60						
3	22153	1	L 08X70						
3	15269	1	L 08X75						
3	21601	1	L 08X80						
3	17128	1	L 10X50						
3	17612	1	L 10X60						
3	16832	1	L 12X45						
3	21016	1	L 12X55						
3	22540	1	L 12X70						
4	04859	8	10X30X03 UNI 6593						
5	05127	16	08X24X02 UNI 6593						
6	00946	8	M08 UNI 6592						
7	00377	4	TE M08X25 UNI 5739						
8	19808	4	TE M08X45 UNI 5737						
9	22156	2							

C 08

RETI G03
NET G03
GRIL DE PROTECTION G03

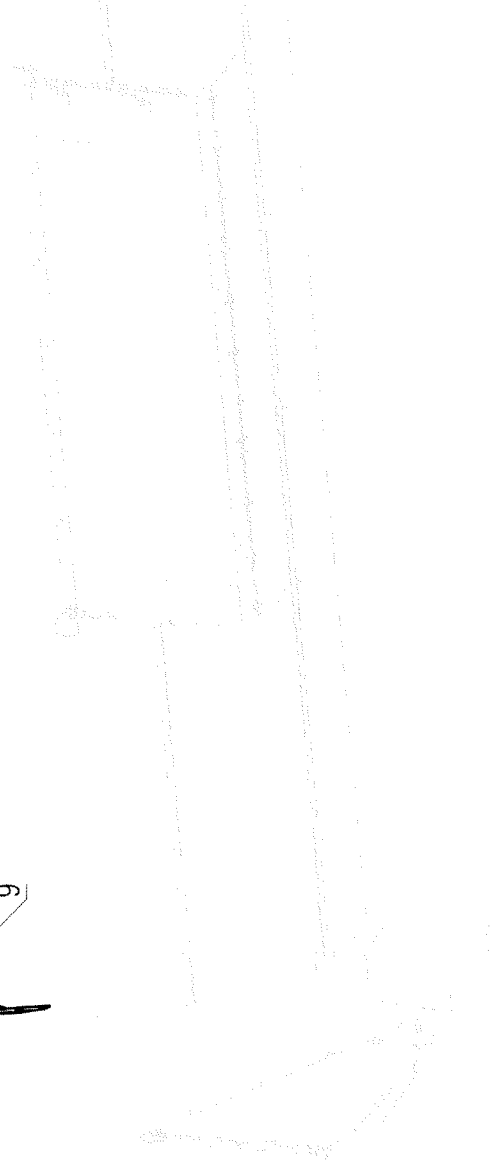
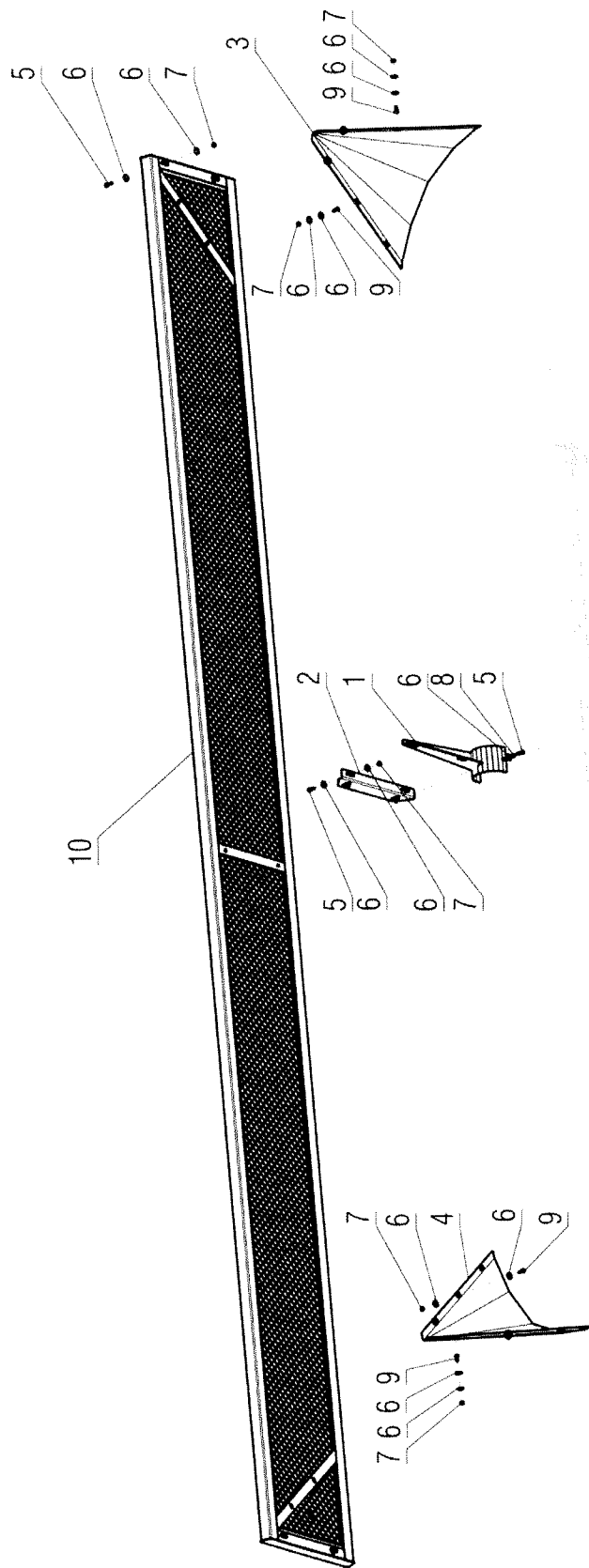

P.	CODICE Code	Qt.	DENOMINAZIONE Description	PREZZO Price	P.	CODICE Code	Qt.	DENOMINAZIONE Description	PREZZO Price
1	17423	1			1				
2	17421	1			2				
3	21741	1			1				
4	21741	1			1				
5	00377	20	TE M08X25 UNI 5739		3				
6	05127	40	08X24X02 UNI 6593		9				
7	04858	10	M8 UNI 7473 AUTOB		2				
8	00916	2	RDE M08 UNI 8842		1				
9	00383	2	TE M08X20 UNI 5739		1				
10	02652	1	10X45 L= 4650						
10	10563	1	10X70 L= 6900						
10	02654	1	11X50 L= 5600						
10	02656	1	12X45 L= 5550						
10	12228	1	2X70 L=1300						
10	17231	1	2X75 L=1350						
10	17511	1	2X90 L=1500						
10	02658	1	4X70 L=2700						
10	02660	1	4X75 L=2850						
10	02662	1	4X80 L=3000						
10	05692	1	5X65 L=3200						
10	02664	1	5X70 L=3400						
10	02666	1	5X75 L=3600						
10	05696	1	5X80 L=3800						
10	02668	1	6X50 L=3100						
10	05694	1	6X55 L=3350						
10	05698	1	6X65 L= 3850						
10	02670	1	6X70 L= 4100						
10	02672	1	6X75 L= 4350						
10	05704	1	6X80 L= 4600						
10	02674	1	7X45 L= 3300						
10	02680	1	7X55 L= 3900						
10	02682	1	7X60 - 9X45 L= 4200						
10	05702	1	7X65 L= 4500						
10	03677	1	7X70 L= 4800						
10	02684	1	7X75 L= 5100						
10	02686	1	7X80 L= 5400						
10	02688	1	8X45 L= 3750		4				
10	05700	1	8X55 L= 4450						
10	02690	1	8X60 L= 4800						
10	05706	1	8X65 L= 5150						
10	02692	1	8X70 L= 5500						
10	07703	1	8X75 L= 5860						
10	20722	1	8X91,5 L= 7005						

C 09

RETI 12FILE G03
12-ROWS NET G03
GRIL DE PROTECTION 12 ÉLÉMENTS G03

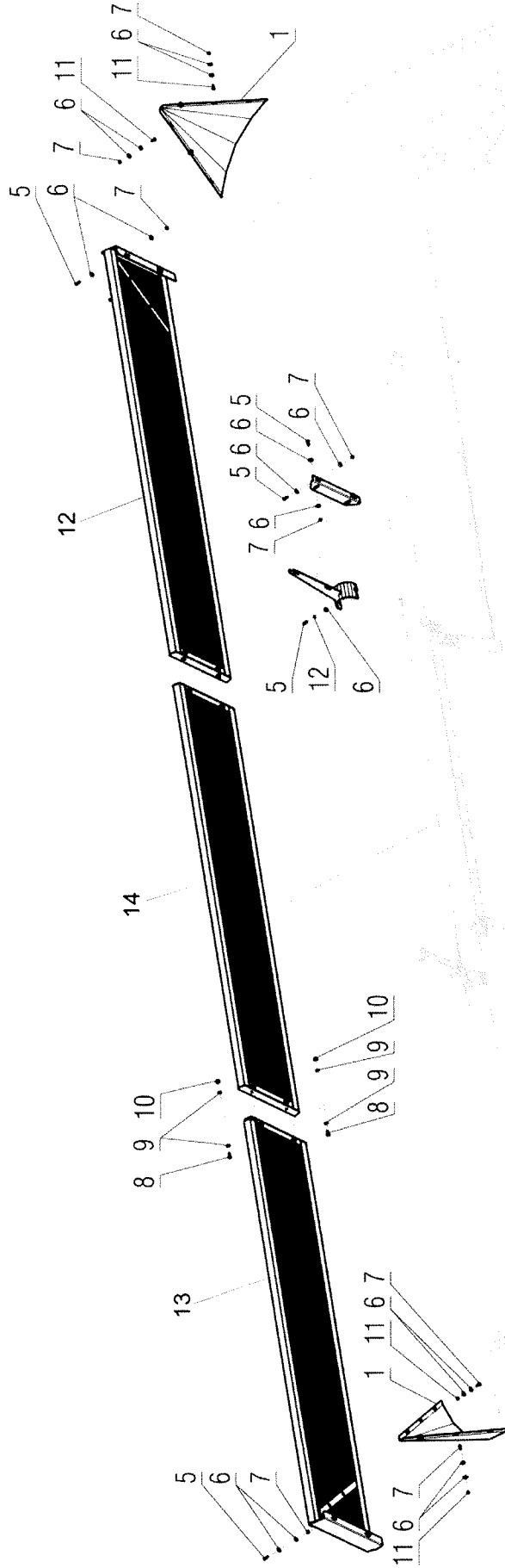

P.	CODICE Code	Qt.	DENOMINAZIONE Description	PREZZO Price	P.	CODICE Code	Qt.	DENOMINAZIONE Description	PREZZO Price
1	21741	2	PROTEZIONE LATERALE						
2	00916	*	RDE M08 UNI 8842						
3	17421	2	ANGOLARE PER RETE						
4	17423	2	SUPPORTO RETE						
5	00377	24	TE M08X25 UNI 5739						
6	05127	50	08X24X02 UNI 6593						
7	04858	24	M08 UNI 7473 AUT.						
8	00375	4	TE M10X25 UNI 5739						
9	00945	8	ROSETTA M10 UNI 6592						
10	04859	4	M10 UNI 7473 AUT.						
11	00574	*	TC M08X20 UNI 5931						
12	22052	1	L 12FILE L=2980						
13	21611	1	R 12FILE L=2980						
14	22174	1	C 12X70 L=2320						
14	22448	1	C 12X75 L=2870						
14	22170	1	C 12X76 L=2980						

C10

COFANATURA IDRAULICA GH3
HYDRAULIC BONNETS GH3
CAPOT HYDRAULIQUES GH3

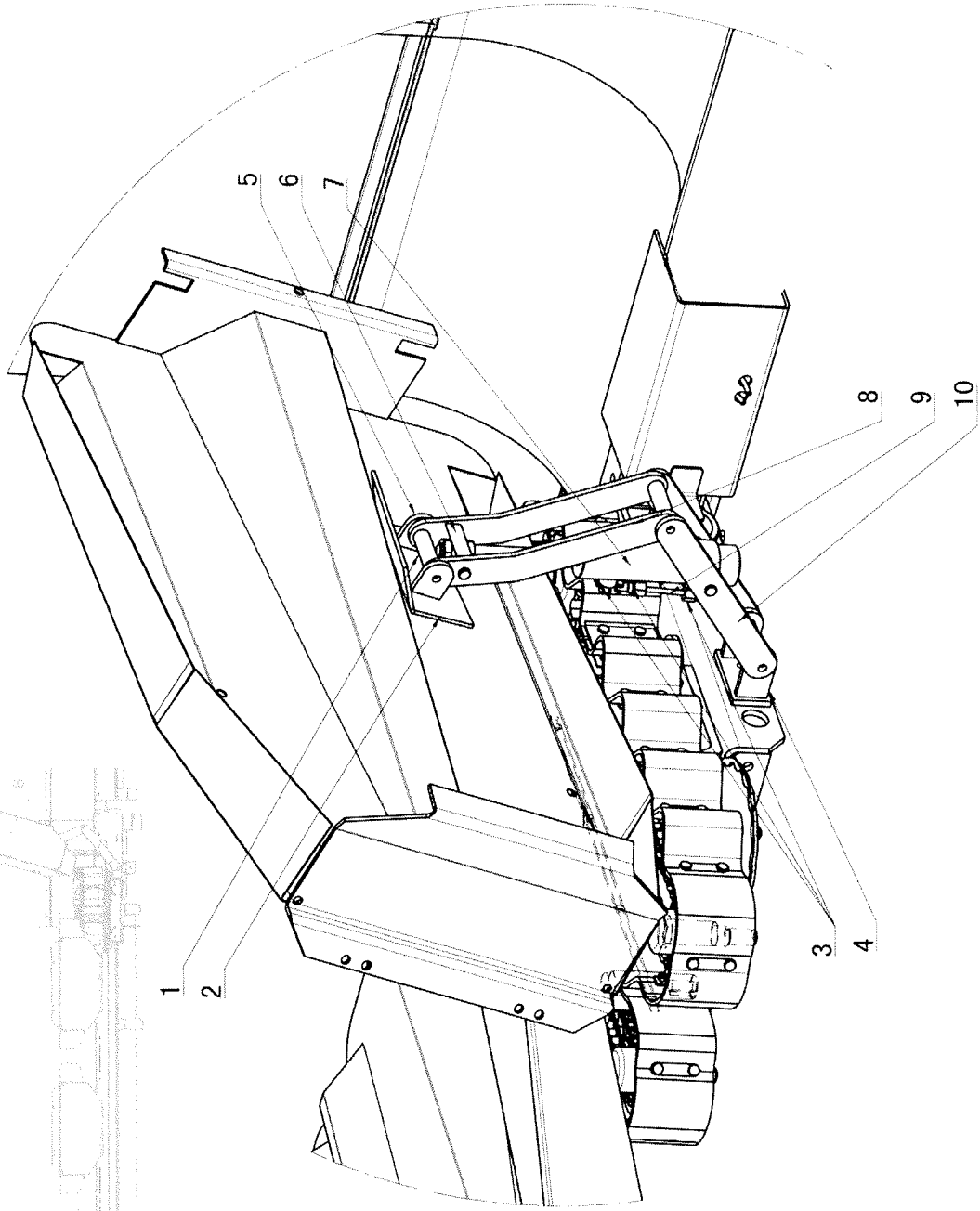
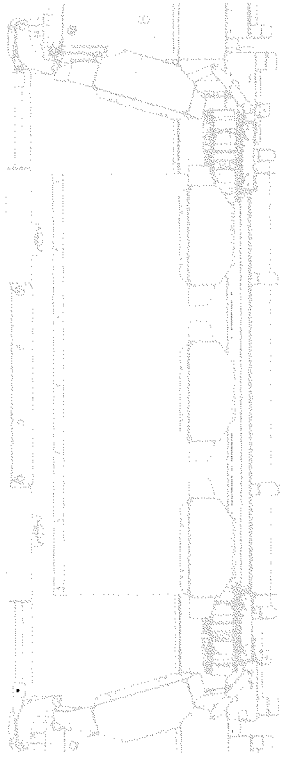

P.	CODICE Code	Qt.	DENOMINAZIONE Description	PREZZO Price	P.	CODICE Code	Qt.	DENOMINAZIONE Description	PREZZO Price
1	18318	2							
2	18310	1	L						
2	18309	1	R						
3	08905	6							
4	18325	2							
5	18314	4							
6	18315	2							
7	17551	2							
8	18322	4							
9	18327	2							
10	18383	4	REG. 75						
10	18326	4	REG. 80						
10	18384	4	REG. 96,5						

C11

COFANATURA IDRAULICA GH3
HYDRAULIC BONNETS GH3
CAPOT HYDRAULIQUES GH3

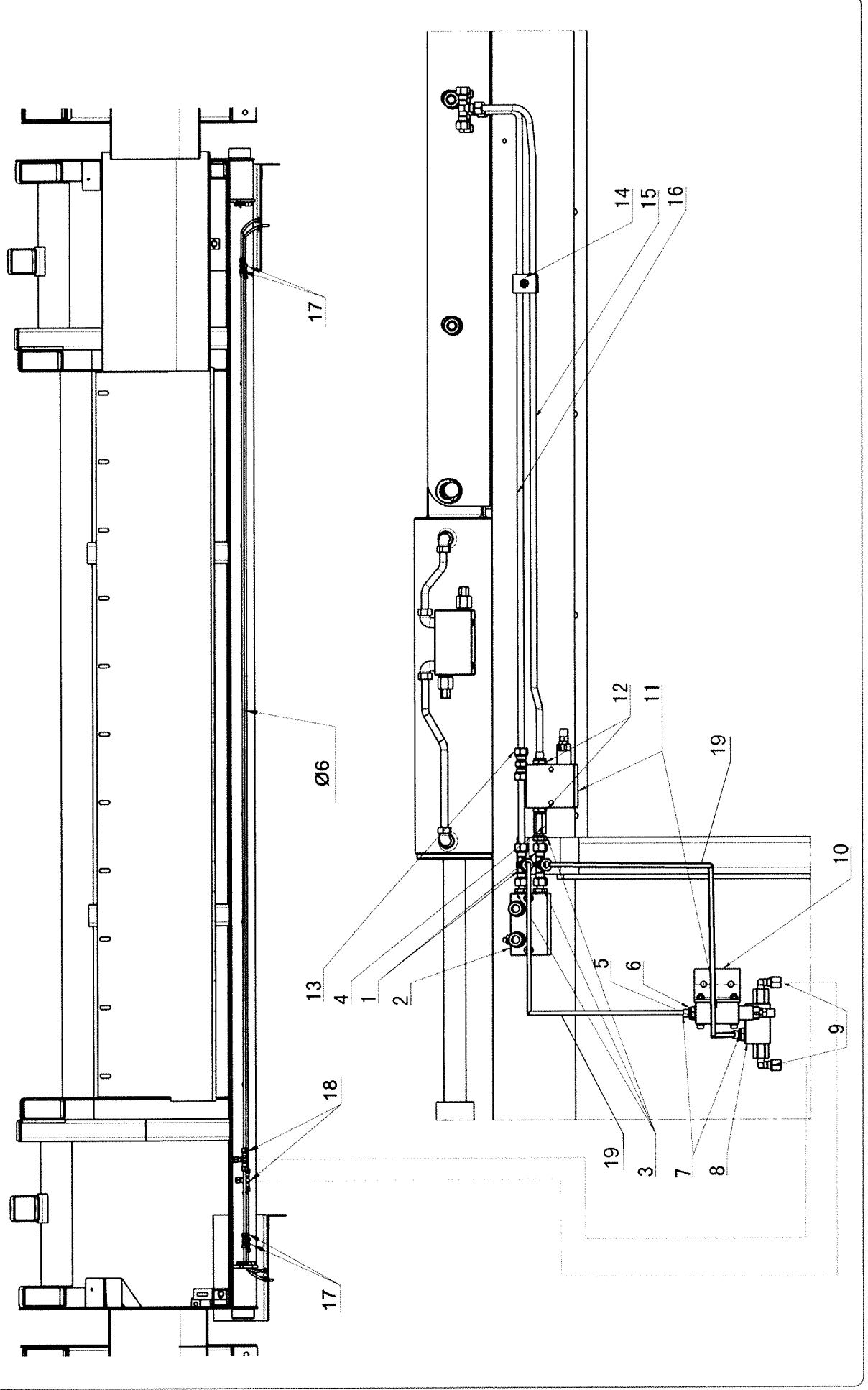

P.	CODICE Code	Qt.	DENOMINAZIONE Description	PREZZO Price	P.	CODICE Code	Qt.	DENOMINAZIONE Description	PREZZO Price
1	01932	2							
2	09231	1							
3	06953	3							
4	10038	1							
5	01920	1							
6	01554	1							
7	01918	2							
8	17497	1							
9	08905	2							
10	18327	1							
11	17498	2							
12	01918	2							
13	01936	1							
14	02927	3							
15	11131	1							
16	11132	1							
17	07850	4							
18	09552	2							
19	11100	2							

F 01

TRASMISSIONE DX
RIGHT TRANSMISSION
DROITE TRANSMISSION

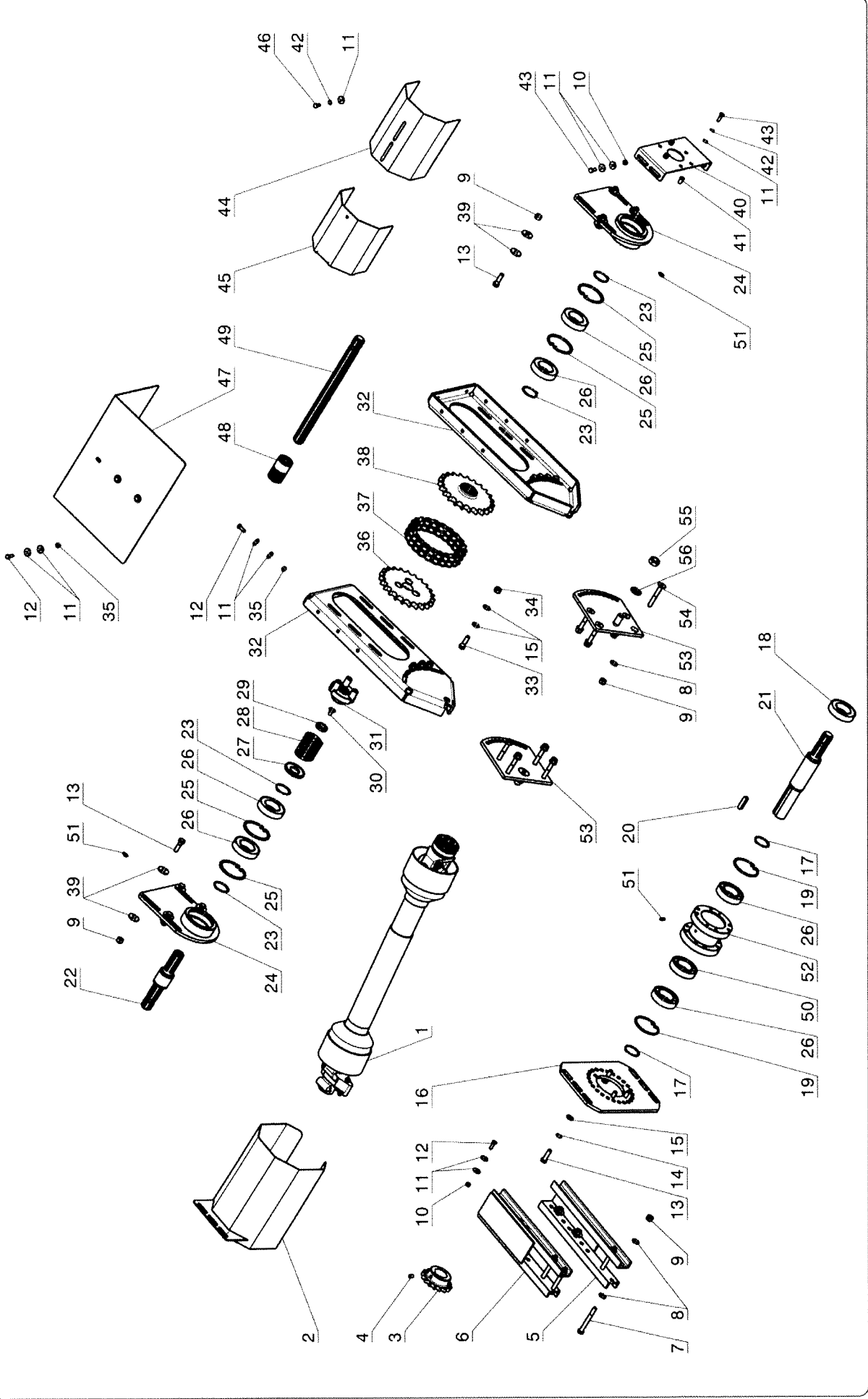
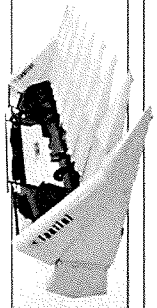

P.	CODICE Code	Qt.	DENOMINAZIONE Description	PREZZO Price	P.	CODICE Code	Qt.	DENOMINAZIONE Description	PREZZO Price
1	14230	*	V60 1"3/8Z06-1"3/8Z06 L 560		52	09087	*		
2	14314	*	06X70		53	13899	*		
3	03261	*	Z16 ASA 60 D 45		54	14359	*	TS M12X90 UNI5933	
4	00987	*	M10X16 UNI 5927 45H		55	04864	*	M20 AUT UNI 7473	
5	21984	*	R L=365		56	00905	*	CONTACT M12	
5	21738	*	R L=410						
6	14090	*	L=365 8 FILE						
6	21740	*	L=410						
7	12850	*	TE M12X100 UNI 5737						
8	03251	1	ASA60 Z15						
8	03252	1	ASA60 Z16						
8	03245	1	ASA60 Z17						
8	18108	1	ASA60 Z18						
8	03246	1	ASA60 Z19						
8	19932	1	ASA60 Z20						
8	03250	1	ASA60 Z21						
8	03253	1	ASA60 Z22						
8	19933	1	ASA60 Z23						
8	03261	1	ASA60 Z24						
8	09150	1	ASA60 Z25						
8	03247	1	ASA60 Z27						
8	09151	1	ASA60 Z28						
8	00947	*	ROSETTA M12 UNI 6592						
9	04860	*	M12 AUT UNI 7473						
10	04858	*	M8 AUT UNI 7473						
11	00946	*	ROSETTA M8 UNI 6592						
12	00377	*	TE M8X25 UNI 5739						
13	00450	*	TE M12X40 UNI 5737						
14	00915	*	RDE M12 UNI 8842						
15	00947	*	M12 UNI 6592						
16	12955	*							
17	09424	*	UNI 7435-75 EST 50						
18	19243	*	55X50-28						
19	09472	*	UNI 7437-75 INT 90						
20	00630	*	14X09X50 UNI 6604-69B						
21	10032	*	1"3/8 Z6 50X350						
22	11823	*	R 50X239						
23	09424	*	UNI 74735-75 EST 50						
24	13900	*							
25	09472	*	UNI 7437-75 INT 90						
26	13941	*	0621-Z						
27	09741	*							
28	10393	*	65X7-78 PASSO 21						
29	11053	*							
30	10703	*	TS M12X30 UNI 5933						
31	12409	*							
32	15530	*	L=622						
33	00439	*	TE M12XZ40 UNI 5739						
34	04860	*	M12 AUT UNI 7473						
35	04858	*	M8 AUT UNI 7473						
36	13881	*	Z023/80 3 FORI						
37	13936	*							
38	13980	*							
39	00932	*	12X36X3 UNI 6593						
40	17830	*							
41	10950	*	FTT M8 SP 0,8-3,5						
42	00916	*	RDE M8 UNI 8842						
43	00377	*	TE M8X25 UNI 5739						
44	17826	*	L=250						
44	17828	*	L=400						
45	17831	*							
46	00383	*	TE M8X20 UNI 5739						
47	13902	*	440X600						
48	15391	*							
49	13903	*							
49	13904	*							
49	09193	*	1"3/8 Z6 L 450						
50	13940	*	6210						
51	00977	*	M8 X1,1						

F 02

TRAMMISSIONE SX LEFT TRANSMISSION GAUCHE TRANSMISSION

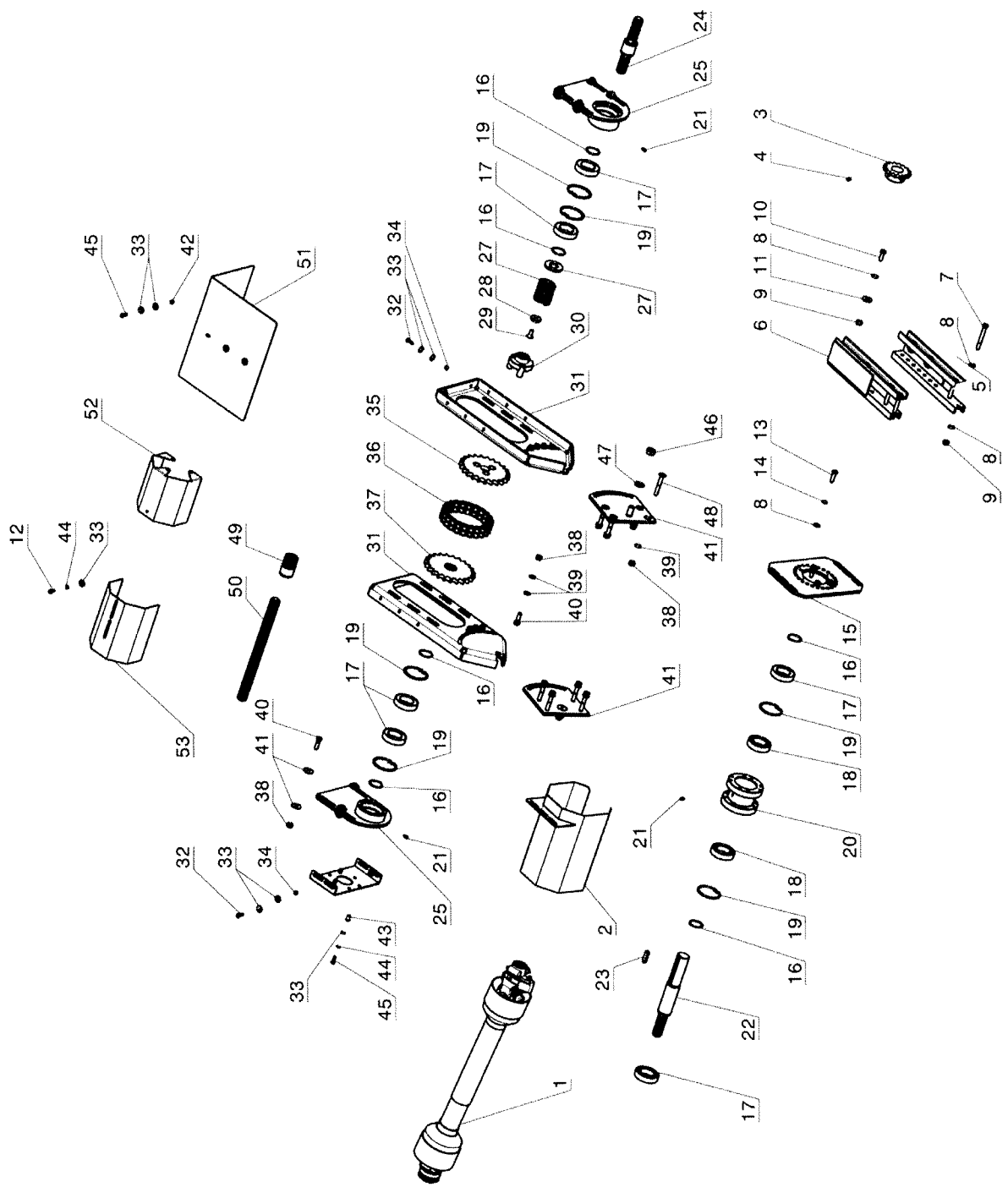
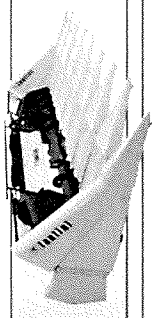

P.	CODICE Code	Qt.	DENOMINAZIONE Description	PREZZO Price	P.	CODICE Code	Qt.	DENOMINAZIONE Description	PREZZO Price
1	14230	*	V60 1"3/8Z06-1"3/8Z06 L 560		52	17824	*		7
2	14317	*	6X70		53	17826	*	L=250	4
3	03251	1	ASA60 Z15		53	17828	*	L=400	5
3	03252	1	ASA60 Z16						
3	03245	1	ASA60 Z17						
3	18108	1	ASA60 Z18						
3	03246	1	ASA60 Z19						
3	19932	1	ASA60 Z20						
3	03250	1	ASA60 Z21						
3	03253	1	ASA60 Z22						
3	19933	1	ASA60 Z23						
3	03261	1	ASA60 Z24						
3	09150	1	ASA60 Z25						
3	03247	1	ASA60 Z27						
3	09151	1	ASA60 Z28						
4	00987	*	GRANO M10X16 UNI 5927						
5	21985	*	L L= 365						
5	21740	*	L L= 410						
5	21984	*	R L= 365						
5	21738	*	R L= 410						
6	14090	*	L=365 8 FILE						
6	21740	*	L=410						
7	12850	*	TE M12X100 UNI 5737						
8	00947	*	ROSETTA M 12 UNI 6592						
9	04860	*	M 12 AUT UNI 7473						
10	00373	*	TE M12X35 UNI 5739						
11	05127	*	8X24X2 UNI 6593						
12	00383	*	TE M8X20 UNI 5739						
13	00450	*	TE M12X40 UNI 5737						
14	00915	*	RDE M12 UNI 8842						
15	12955	*							
16	09424	*	UNI 7435-75 EST 50						
17	13941	*	06210-Z						
18	13940	*	6210						
19	09472	*	UNI 7435-75 EST 90						
20	09087	*							
21	00977	*	M8 X 1,1						
22	13903	*							
22	13904	*							
22	10032	*	1"3/8 Z6						
23	00630	*	14X09X50 UNI 6604-69B						
24	13879	*	L						
25	13900	*							
26	00000	*							
27	10393	*							
28	08509	*							
29	00530	*	TS M10X25 UNI 5933						
30	12409	*							
31	15530	*	L=622						
32	00377	*	TE M8X25 UNI 5739						
33	00946	*	ROSETTA M 8 UNI 6592						
34	04858	*	M8 AUT UNI 7473						
35	13881	*	Z023/80 3 FORI						
36	13936	*	ASA80-2 22 PASSI						
37	13980	*	Z023/80						
38	04860	*	M12 UNI 7473						
39	00947	*	M12 UNI 6592						
40	00450	*	TE M12X40 UNI 5737						
41	00932	*	12X36X03 UNI 6593						
42	17830	*							
43	10950	*	FTT M08 SP 0,8-3,5						
44	00916	*	RDE M8 UNI 8842						
45	00377	*	TE M08X25 UNI 5739						
46	04864	*	M20 AUT UNI 7473						
47	00905	*	CONTACT M12						
48	14359	*	TS M12X90 UNI 5933						
49	15391	*							
50	09193	*	1"3/8 Z6 L 450						
51	13902	*	440X600						

F 03

TRAMMISSIONE LATERALE G03
SIDE TRANSMISSION G03
TRANSMISSION LATERAL G03

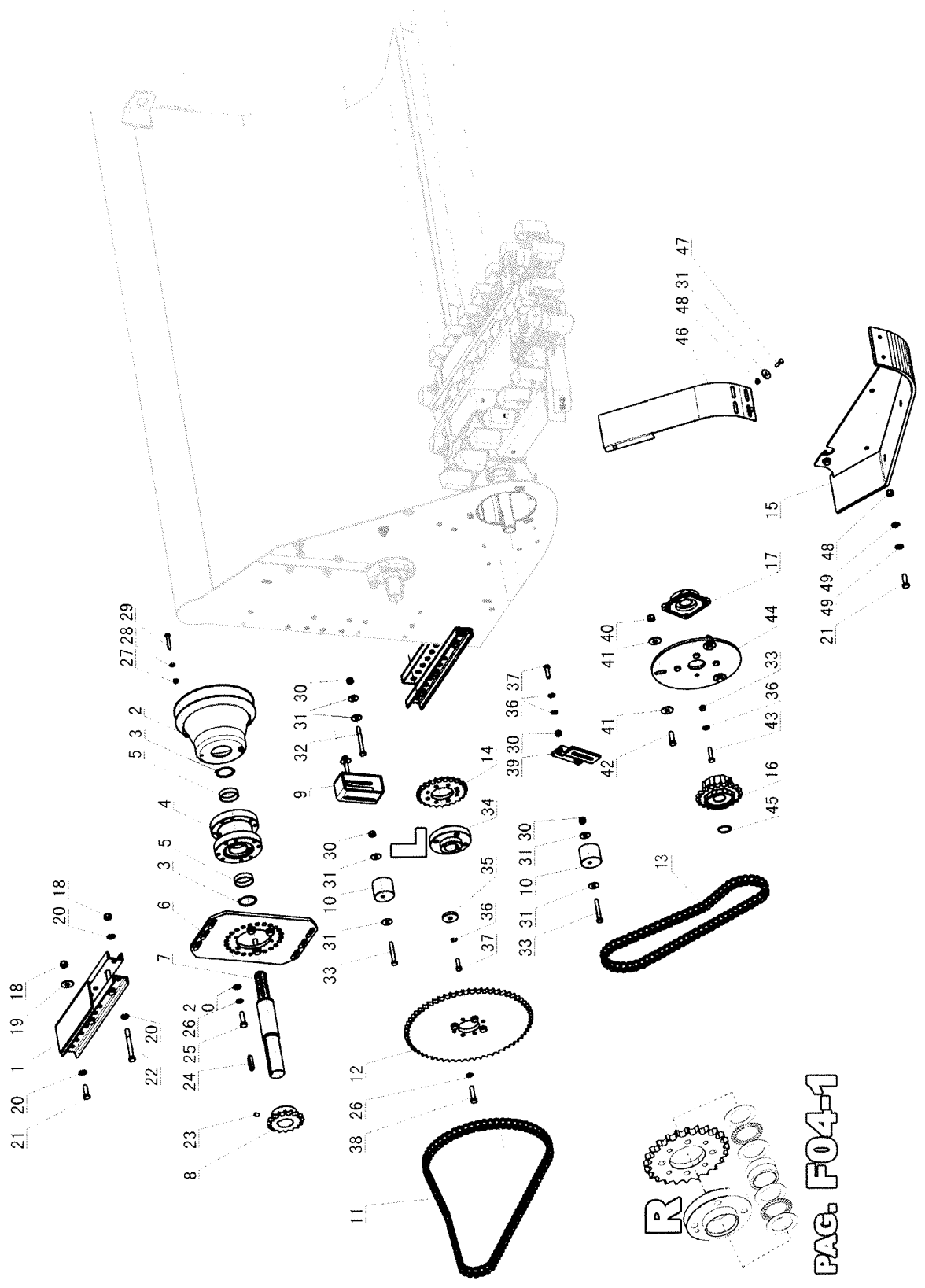
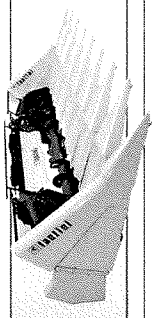

P.	CODICE Code	Qt.	DENOMINAZIONE Description	PREZZO Price	P.	CODICE Code	Qt.	DENOMINAZIONE Description	PREZZO Price
1	14090	1	L= 365 mm						
1	21740	1	L= 410 mm						
1	12976	1	L= 475mm						
2	12843	1							
3	09424	1	UNI 7435 - 75 EST 30						
4	09780	1							
5	11266	1							
6	12276	1							
7	10032	1							
8	03251	1	ASA60 Z15						
8	03252	1	ASA60 Z16						
8	03245	1	ASA60 Z17						
8	18108	1	ASA60 Z18						
8	03246	1	ASA60 Z19						
8	19932	1	ASA60 Z20						
8	03250	1	ASA60 Z21						
8	03253	1	ASA60 Z22						
8	19933	1	ASA60 Z23						
8	03261	1	ASA60 Z24						
8	09150	1	ASA60 Z25						
8	03247	1	ASA60 Z27						
8	09151	1	ASA60 Z28						
9	22053	1							
10	03709	1							
11	100831	1	Z15 = 107 PASSI/CONNECTING LINKS ASA6						
11	100830	1	Z20 = 109 PASSI/CONNECTING LINKS ASA6						
11	100832	1	Z23 = 111 PASSI/CONNECTING LINKS ASA6						
12	06023	1	Z 62						
12	03517	1	Z 70						
12	08997	1	Z 75						
13	03047	1	67 PASSI/CONNECTING LINKS ASA60						
14	03418	1	Z24						
14	03602	1	Z26						
15	22158	1	L						
15	22157	1	R						
16	20143	1	65 dNm						
17	01406	1	SAF 207						
18	04860	7	M12 UNI 7473						
19	05127	20	08X24X02 UNI 6593						
20	00947	4	M12 UNI 6592						
21	00373	4	TE M12X35 UNI 5739						
22	12850	3	TE M12X100 UNI 5737						
23	00987	*	M10X16 UNI 5927						
24	00630	4	14X09X050 UNI 6604-69B						
25	00439	4	TE M12X40 UNI 5737						
26	00915	4	RDE M12 UNI8842						
27	04858	2	M8 AUTOB UNI 7473						
28	00946	*	M08 UNI 6592						
29	19808	2	TE M08X45 UNI 5737						
30	04859	20	M10 UNI 7473 AUTOB						
31	00928	*	10X30X30						
32	00401	4	TE M10X95 UNI 5737						
33	00393	2	TE M10X75 UNI 5737						
34	03711	2							
35	03319	2	13X46X8						
36	00945	12	M10 UNI 6592						
37	00384	4	TE M10X30 UNI 5739						
38	05008	4	TE M12X45 UNI 5738						
39	05248	2							
40	04860	6	M12 UNI 7473 AUTOB						
41	01064	*	RONDELLA 13X40X3						
42	00373	3	TE M12X35 UNI 5739						
43	06003	8	TE M10X40 UNI 5737						
44	13284	2							
45	00604	2	UNI 7435 - 75 EST 40						
46	22190	*							
47	00377	2	TE M08X25 UNI 5739						
48	04858	13	M8 UNI 7473 AUTOB						
49	00947	*	M12 UNI 6592						

F 04-1

TRAMMISSIONE LATERALE GH3
SIDE TRANSMISSION GH3
TRANSMISSION LATERAL GH3

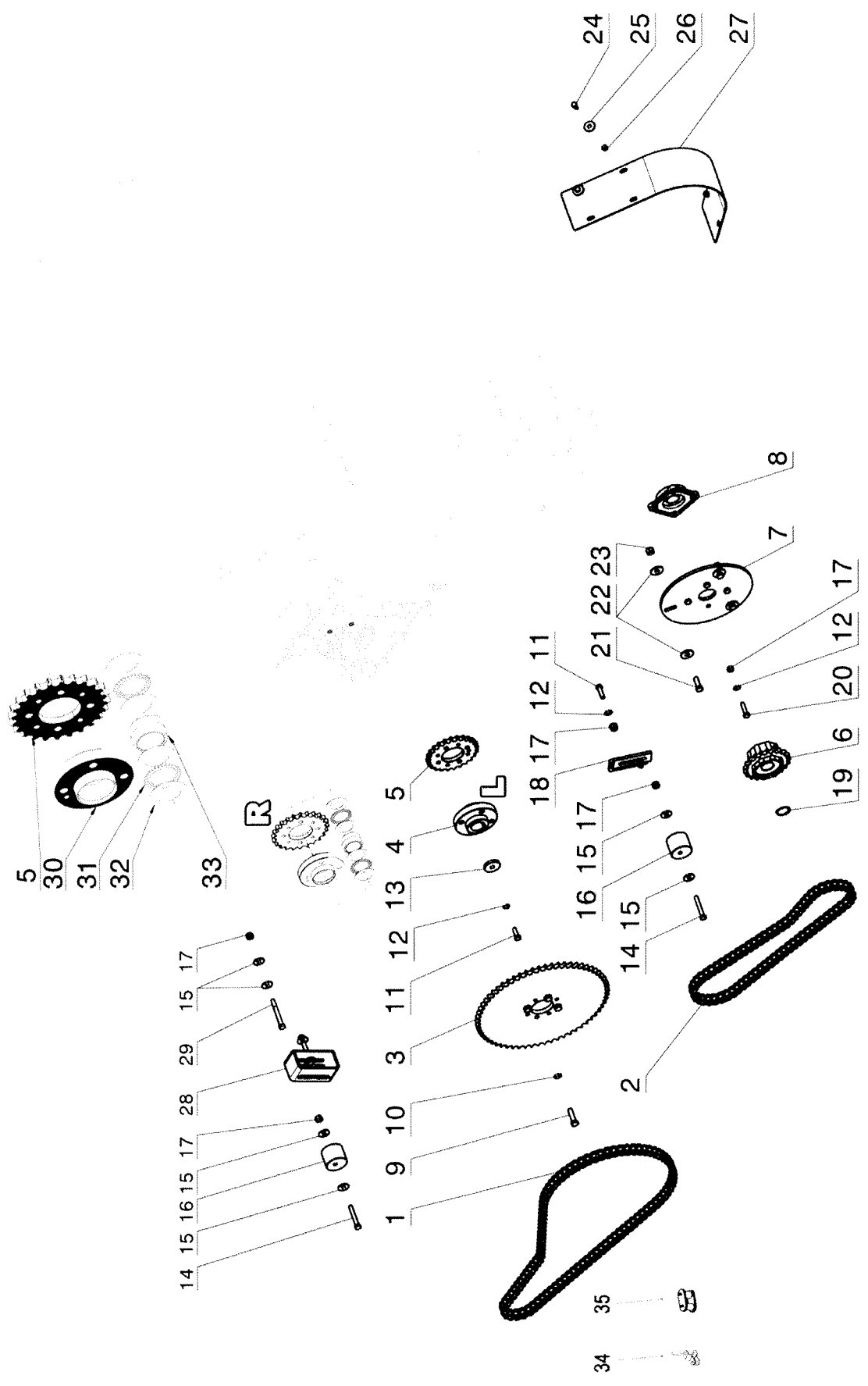
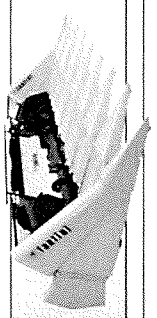

P.	CODICE Code	Qt.	DENOMINAZIONE Description	PREZZO Price	P.	CODICE Code	Qt.	DENOMINAZIONE Description	PREZZO Price
1	100834	1	Z15 = 105 PASSI/CONNECTING LINKS ASA6						
1	100835	1	Z15 = 139 PASSI/CONNECTING LINKS ASA6						
1	23877	1	Z20 = 113 PASSI/CONNECTING LINKS ASA6						
1	100833	1	Z21 = 115 PASSI/CONNECTING LINKS ASA6						
2	03047	1	67 PASSI/CONNECTING LINKS ASA60						
3	03517	1	ASA060 Z 070						
4	03711	1							
5	03418	1	L ASA060 Z 024						
6	20143	1	65 dNm						
7	13284	1							
8	01406	1							
9	05008	1	TE M12X045 UNI 5738						
10	00915	1	RDE M12 UNI 8842						
11	00384	1	TE M10X030 UNI 5739						
12	00945	1	M 10 UNI 6592						
13	03319	1	13X46X8						
14	00393	1	TE M10X75 UNI 5737						
15	00928	1	10X30X3 UNI 6593						
16	03709	1							
17	04859	1	M10 AUT UNI 7473						
18	05248	1							
19	00590	1	UNI 7435-75 EST 35						
20	06003	1	TE M10X40 UNI 5737						
21	00373	1	TE M12X35 UNI 5739						
22	00932	1	12X36X3 UNI 6593						
23	04860	1	M12 AUT UNI 7473						
24	00383	1	TE M8X20 UNI 5739						
25	00928	7	10X30X3 UNI 6593						
26	04858	20	M8 AUT UNI 7473						
27	21838	4							
28	22053	4							
29	00401	3	TE M10X95 UNI 5737						
30	03097	1	R						
31	03766	2	AXK 4060						
32	03767	4	AS4060						
33	03761	2	NKJ 4030A						
34	03114	*							
35	03125	*							

F 04-2

TRASMISSIONE LATERALE 12 FILE GH3
SIDE TRANSMISSION 12 ROWS GH3
TRANSMISSION LATERAL 12 ÉLÉMENTS GH3

UP TO 2014

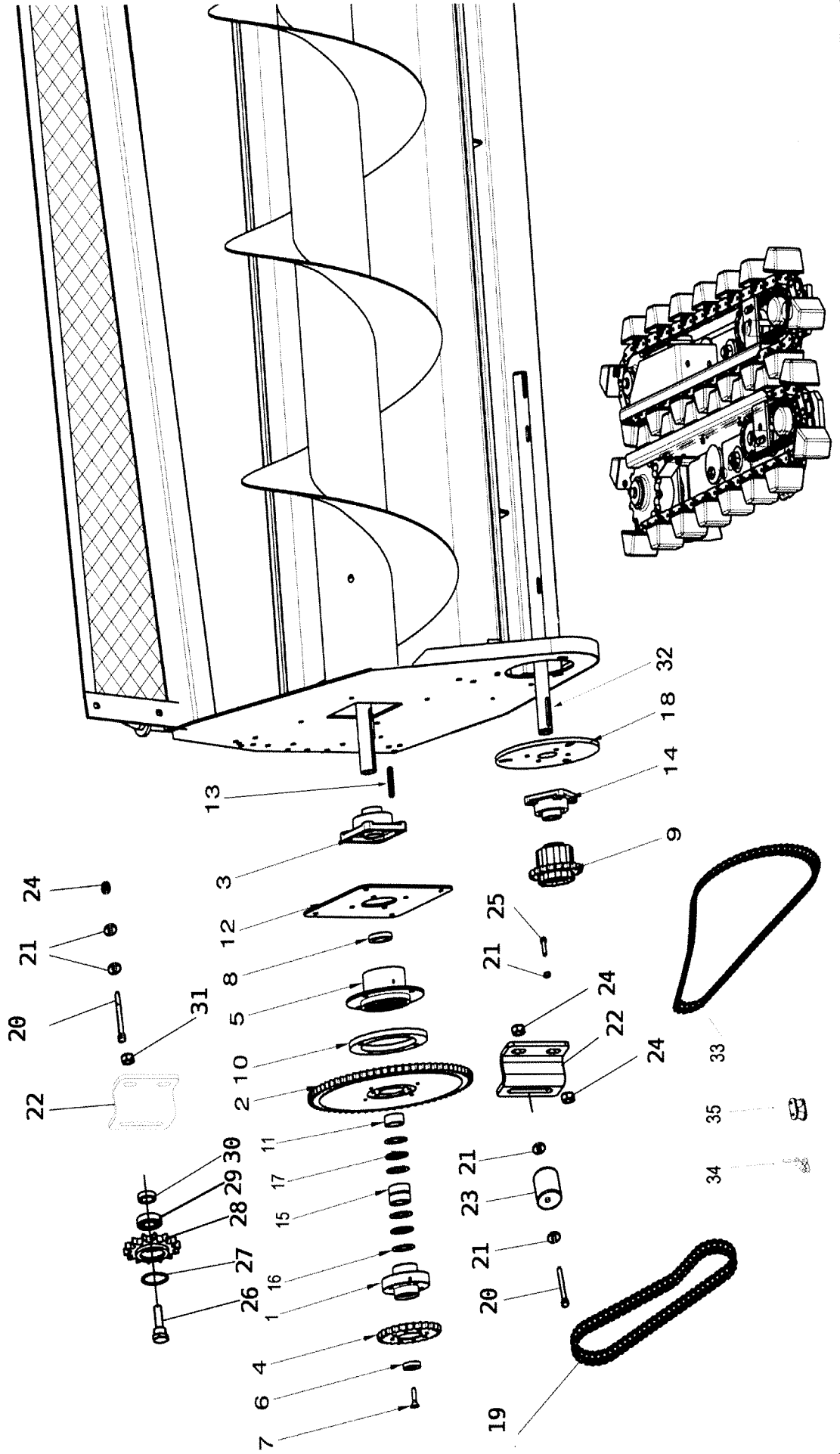

P.	CODICE Code	Qt.	DENOMINAZIONE Description	PREZZO Price	P.	CODICE Code	Qt.	DENOMINAZIONE Description	PREZZO Price
1	03097	1							
2	22769	1	ASA060 Z70						
3	01410	1							
4	03602	1	ASA060 Z 026						
5	22774	1							
6	22766	1							
7	00511	1	TPSEI M10X035 UNI 5933 08.8						
8	23233	1	60.0X040.0-009						
9	22923	1	90 dNm - 12 FILE						
10	22764	1							
11	22768	1	55.0X040.0-016.5						
12	22304	1							
13	00607	1	10X08X050 UNI 6604-69B						
14	01406	1							
15	03761	1	NKJ 4030A						
16	03767	4	AS4060						
17	03766	2	AXK 4060						
18	12936	1							
19	23865	1	75 PASSI/CONNECTING LINKS ASA60HE						
20	00401	3	TE M10X095 UNI 5737 08.8						
21	00945	10	M10 UNI 6592						
22	23284	2							
23	22132	1							
24	00476	5	M10 UNI 5588						
25	00384	2	TE M10X030 UNI 5739						
26	03534	1							
27	00591	1							
28	19807	1	ASA060 Z 014						
29	01265	1	6004-2RS						
30	06814	1	30.0X021.0-009						
31	04860	1							
32	22311	1	L=777 12 FILE REG. 70-75-80						
33	23877	1	Z20 = 113 PASSI/CONNECTING LINKS ASAE						
33	23877	1	Z21 = 113 PASSI/CONNECTING LINKS ASAE						
34	03114	*							
35	03125	*							

F 04-3

TRASMISSIONE LATERALE 12 FILE GH3
SIDE TRANSMISSION 12 ROWS GH3
TRANSMISSION LATERAL 12 ÉLÉMENTS GH3

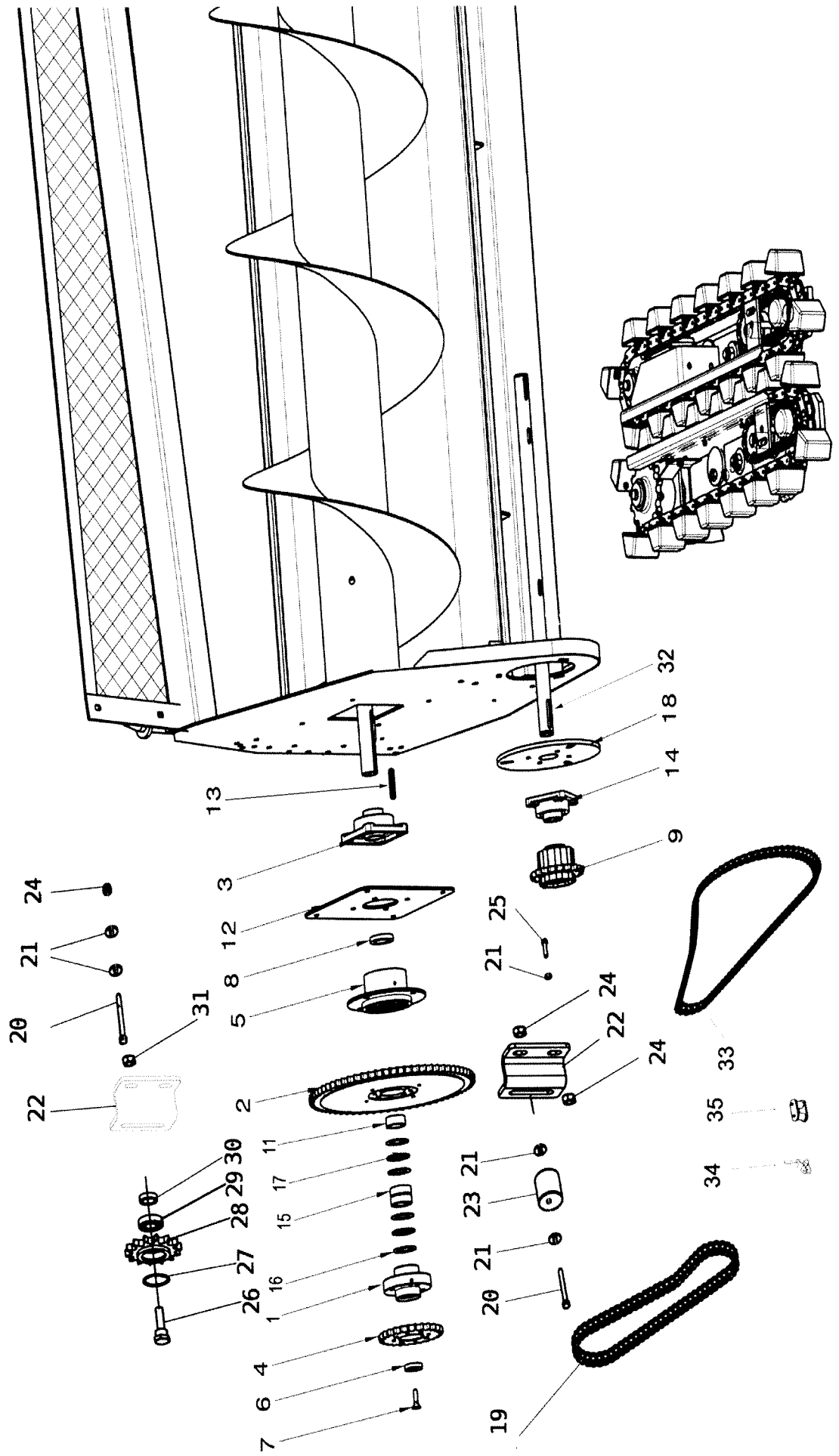
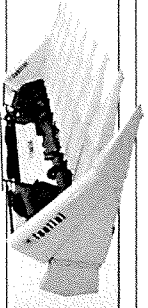

P.	CODICE Code	Qt.	DENOMINAZIONE Description	PREZZO Price	P.	CODICE Code	Qt.	DENOMINAZIONE Description	PREZZO Price
1	03097	1							
2	22769	1	ASA060 Z70						
3	01410	1							
4	03602	1	ASA060 Z 026						
5	22774	1							
6	22766	1							
7	00511	1	TPSEI M10X035 UNI 5933 08.8						
8	23233	1	60.0X040.0-009						
9	22923	1	90 dNm - 12 FILE						
11	22768	1	55.0X040.0-016.5						
12	22304	1							
13	00607	1	10X08X050 UNI 6604-69B						
14	01406	1							
15	03761	1	NKJ 4030A						
16	03767	4	AS4060						
17	03766	2	AXK 4060						
18	12936	1							
19	23865	1	75 PASSI/CONNECTING LINKS ASA60HE						
20	00401	3	TE M10X095 UNI 5737 08.8						
21	00945	10	M10 UNI 6592						
22	23284	2							
23	22132	1							
24	00476	5	M10 UNI 5588						
25	00384	2	TE M10X030 UNI 5739						
26	03534	1							
27	00591	1							
28	19807	1	ASA060 Z 014						
29	01265	1	6004-2RS						
30	06814	1	30.0X021.0-009						
31	04860	1							
32	22311	1	L=777 12 FILE REG. 70-75-80						
33	23877	1	Z20 = 113 PASSI/CONNECTING LINKS ASAE						
33	23877	1	Z21 = 113 PASSI/CONNECTING LINKS ASAE						
34	03114	*							
35	03125	*							

F 05

TRAMMISSIONE 12 FILE GH3
12-ROWS TRANSMISSION GH3
TRANSMISSION 12 ÉLÉMENTS GH3

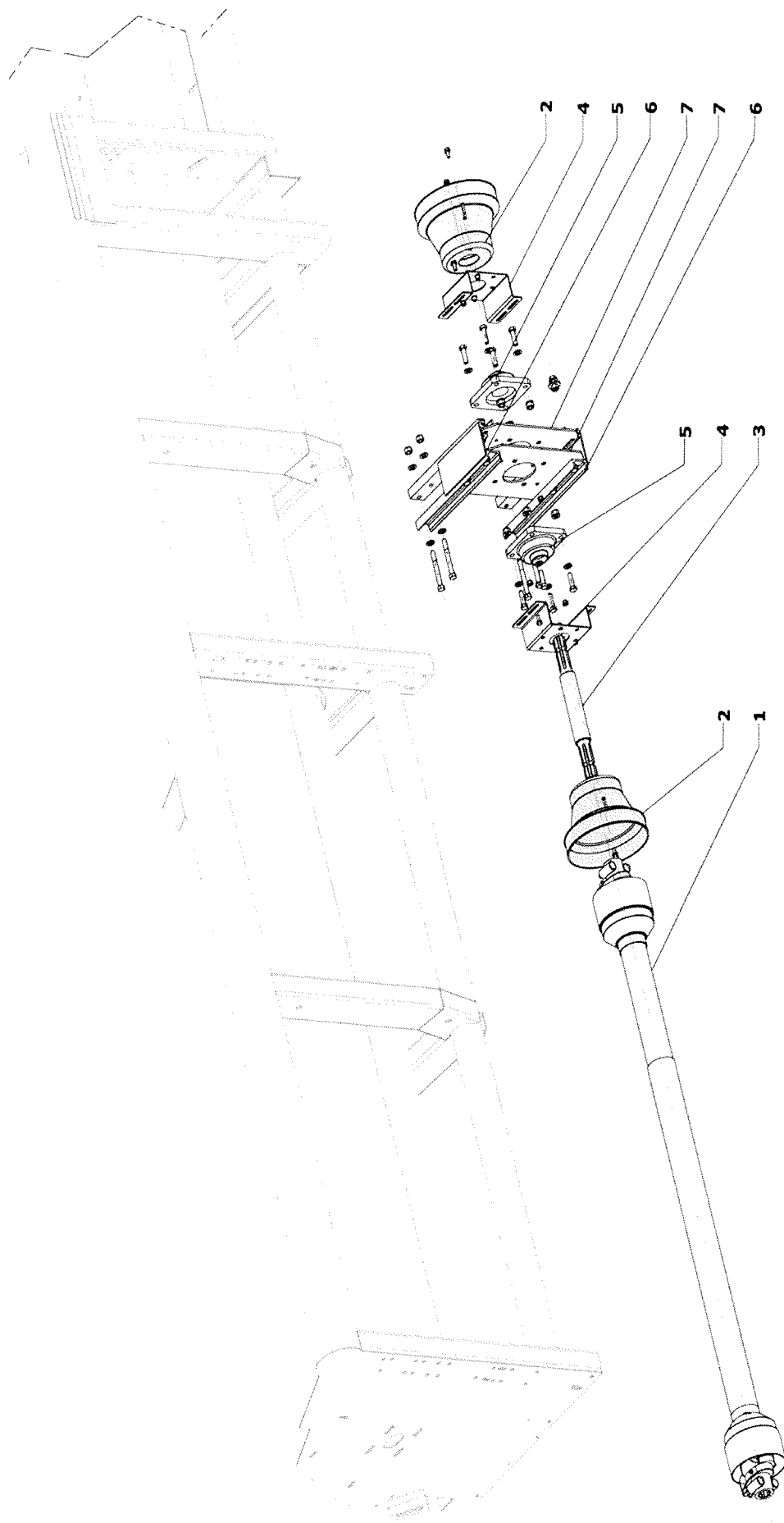

P.	CODICE Code	Qt.	DENOMINAZIONE Description	PREZZO Price	P.	CODICE Code	Qt.	DENOMINAZIONE Description	PREZZO Price
1	14803	2		9					
2	12843	4		1					
3	18081	2							
4	18113	4							
5	01411	4							
6	14090	4							
7	18112	4		2					

F 06

CARDANI V60/V80 - GIUNTI
DRIVE SHAFTS V60/V80 - JOINT
CARDAN V60/V80 - JOINT

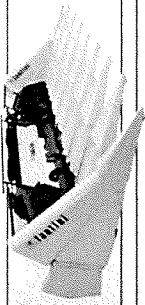

25
1
3
6

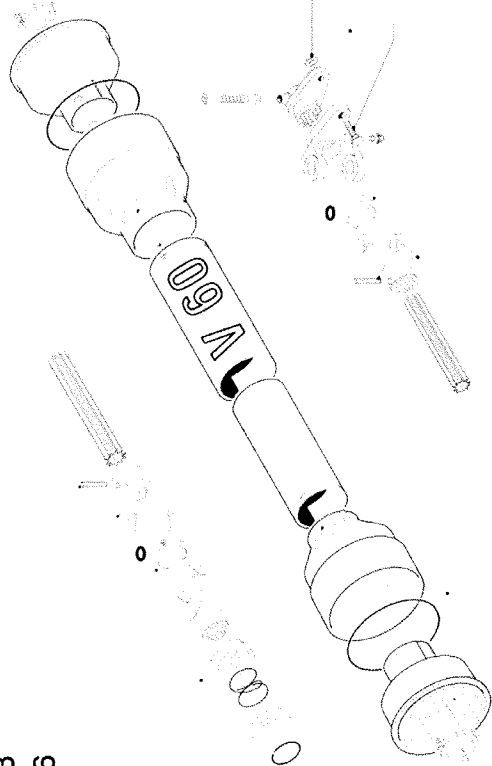

26
9
27
3
24
7

15
16
17

10

23

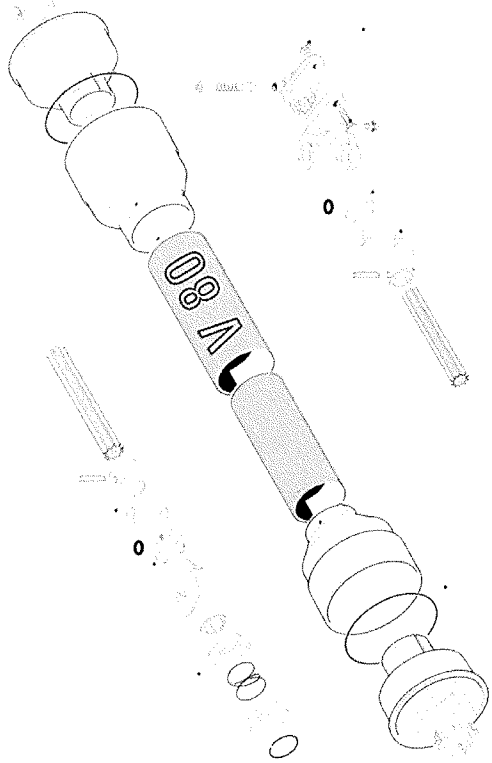

18
19
20
16
21

8

22

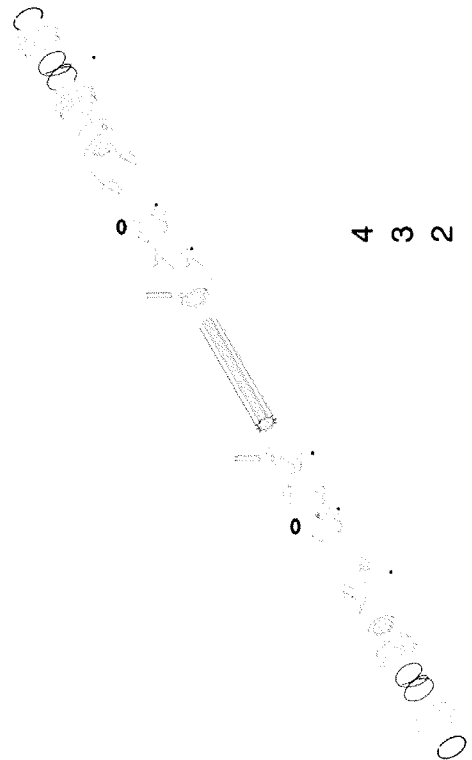

4
3
2

2
3
4

11

108

12
3
13
3
14

5

P.	CODICE Code	Qt.	DENOMINAZIONE Description	PREZZO Price	P.	CODICE Code	Qt.	DENOMINAZIONE Description	PREZZO Price
1	14888	1							
2	13959	2	1"3/8 Z6						
3	14745	2	SERIE 60						
4	14895	2							
5	14055	1	V60 1"3/8 Z6 + 1"3/8 Z6 L= 406						
5	14364	1	V60 1"3/8 Z6 + 1"3/8 Z6 L= 470						
5	14746	1	V60 1"3/8 Z6 + 1"3/8 Z6 L= 536						
5	14433	1	V60 1"3/8 Z6 + 1"3/8 Z6 L= 568						
5	14432	1	V60 1"3/8 Z6 + 1"3/8 Z6 L= 591						
6	13960	1	V60 1"3/8 Z21						
6	13959	1	V60 1"3/8 Z6						
6	13962	1	V60 ESA. 27						
6	13961	1	V60 ESA. 28.5						
7	14889	1							
8	14894	1	L= 660						
8	16091	1	L=1410						
8	16227	1	L=1770						
8	13107	1	L=410						
9	14893	1							
10	14294	1	V60 1"3/8 Z6 + E 27 L=924						
10	14282	1	V60 1"3/8 Z6 + 1"3/8 Z21 L= 1450						
10	14053	1	V60 1"3/8 Z6 + 1"3/8 Z21 L= 924						
10	13908	1	V60 1"3/8 Z6 + 1"3/8 Z6 L= 890						
10	14052	1	V60 1"3/8 Z6 + 1"3/8 Z6 L= 924						
10	14803	1	V60 1"3/8 Z6 + 1"3/8 Z6 L=1450						
10	14054	1	V60 1"3/8 Z6 + E 28.5 L= 924						
10	14801	1	V60 1"3/8 Z6 + E 28.5 L=1450						
11	15350	1	60 1"3/8 Z6 + E 27 H108						
11	15349	1	60 1"3/8 Z6 + E 28.5 H108						
11	15348	1	60 1"3/8 Z6 + Z21 H108						
11	15347	1	60 1"3/8 Z6 + Z6 H108						
12	14892	1	V60 1"3/8 Z21						
12	13962	1	V60 ESA. 27						
12	13961	1	V60 ESA. 28.5						
13	15547	1							
14	14891	2	V60 1"3/8 Z6						
15	19955	1							
16	17737	2	SERIE 80						
17	17738	1	V80 1"3/8 Z06						
17	17739	1	V80 1"3/8 Z21						
17	18020	1	V80 1/8 E28.5						
17	18606	1	V80 3/4 Z20						
18	04861	1							
19	19959	1	V80 1"3/8Z06						
20	05971	1	TE M12X065 UNI 5738 08.8						
21	19956	1	12 UNI 7473 A 1,25						
22	19958	1	V80						
23	17735	1	V80 1"3/8 Z6 - + L=2000 BT						
23	17736	1	V80 1"3/8 Z6 - 1"3/8 Z6 L=2000						
23	18584	1	V80 1"3/8 Z6 - 1"3/8 Z6 L=2000 BT						
23	18027	1	V80 1"3/8 Z6 - 1"3/8 Z21 L=2000 BT						
23	18583	1	V80 1"3/8 Z6 - 1/8 E28.5 L=2000 BT						
23	18607	1	V80 1"3/8 Z6 - 3/4 Z20 L=2000 BT						
24	19960	1	10X90 DIN 1481						
25	00999	1	10X80 DIN 1481						
26	04859	1	M10 UNI 7473						
27	00385	1	TE M10X060 UNI 5739 08.8						

01

COCLEE G03
AUGER G03
VIS D'ALIMENTATION G03

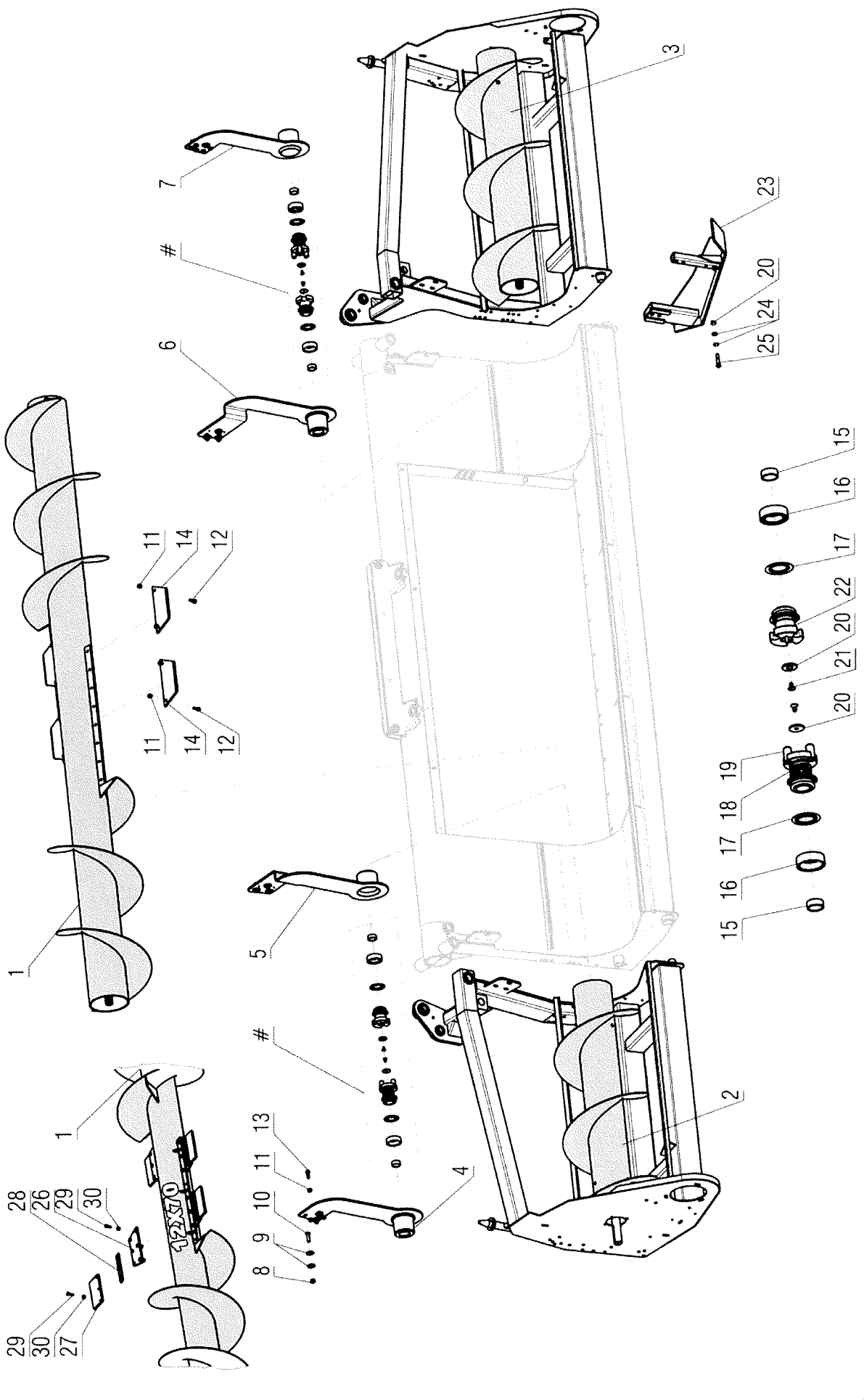
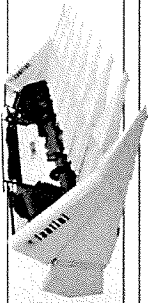

P.	CODICE Code	Qt.	DENOMINAZIONE Description	PREZZO Price	P.	CODICE Code	Qt.	DENOMINAZIONE Description	PREZZO Price
1	17210	1	C 12X45 - 6X96,5 - 8X60 L= 3610						
1	22526	1	C 12X70 L= 4303						
1	13887	1	C 6 FILE L= 2968		7				
1	14288	1	C 8 FILE L= 3260		7				
1	22568	1	C 9X45 L= 3160						
2	16820	1	R 10X50 L=1030						
2	17617	1	R 10X60 L=1153						
2	21715	1	R 10X75 L=1394						
2	16783	1	R 12X45 L=934						
2	21000	1	R 12X55 L=1094						
2	22527	1	R 12X70 L=1926						
2	14377	1	R 6X75 L= 649		9				
2	17980	1	R 6X80 L=628						
2	22313	1	R 6X96,5 L=865						
2	13885	1	R 8X50 L=523		4				
2	17586	1	R 8X60 L=553						
2	14367	1	R 8X75 L=1253		0				
2	22101	1	R 8X80 L=1342						
2	22567	1	R 9X45 L=478						
3	13886	1	L 8X50 L=523		4				
3	16821	1	L 10X50 L=1030						
3	17615	1	L 10X60 L=1153						
3	21716	1	L 10X75 L=1394						
3	16784	1	L 12X45 L=934						
3	21009	1	L 12X55 L=1094						
3	22528	1	L 12X70 L=1926						
3	14378	1	L 6X75 L=649		0				
3	17983	1	L 6X80 L=628						
3	22398	1	L 6X96,5 L=865						
3	17584	1	L 8X60 L=553		0				
3	14368	1	L 8X75 L=1253						
3	22102	1	L 8X80 L=1342						
3	22569	1	L 9X45 L=478						
4	14115	1	R RIB.		0				
4	22529	1	R RIB. 12X70						
5	14117	1	R CEN.						
5	22531	1	R CEN. 12X70						
6	14118	1	L CEN.						
6	22532	1	L CEN. 12X70						
7	14116	1	L RIB.						
7	22530	1	L RIB. 12X70						
8	04860	20	M12 AUT UNI 7473						
9	09361	24	33x13x5						
10	00374	20	TE M12X40 UNI 5739						
11	04859	8	M10 AUT UNI 7473						
12	00384	8	TE M10X30 UNI 5739						
13	22028	6	TE M10X30 IVE 0119						
14	12694	4							
15	08510	4							
16	01287	4	02207-2RS						
17	01330	8	NILOS 6207 JV						
18	03451	2							
19	09001	2							
20	08508	4							
21	00512	4	TS M08X16 UNI 5933						
22	09002	2							
23	21812	1	L						
23	21811	1	R						
24	00947	8	M12 UNI 6592						
25	00373	4	TE M12X35 UNI 5739						
26	21980	4	12 FILE L= 256						
27	21941	4	12 FILE L= 192						
28	21979	4	12 FILE L= 196						
29	00403	8	12 FILE TE M10x35 UNI 5739						
30	04859	22	12 FILE UNI 7473						

02

COCLEE 12 FILE G03
AUGER WITH CLUTCH 12 ROWS G03
VIS D'ALIMENTATION 12 ÉLÉMENTS G03

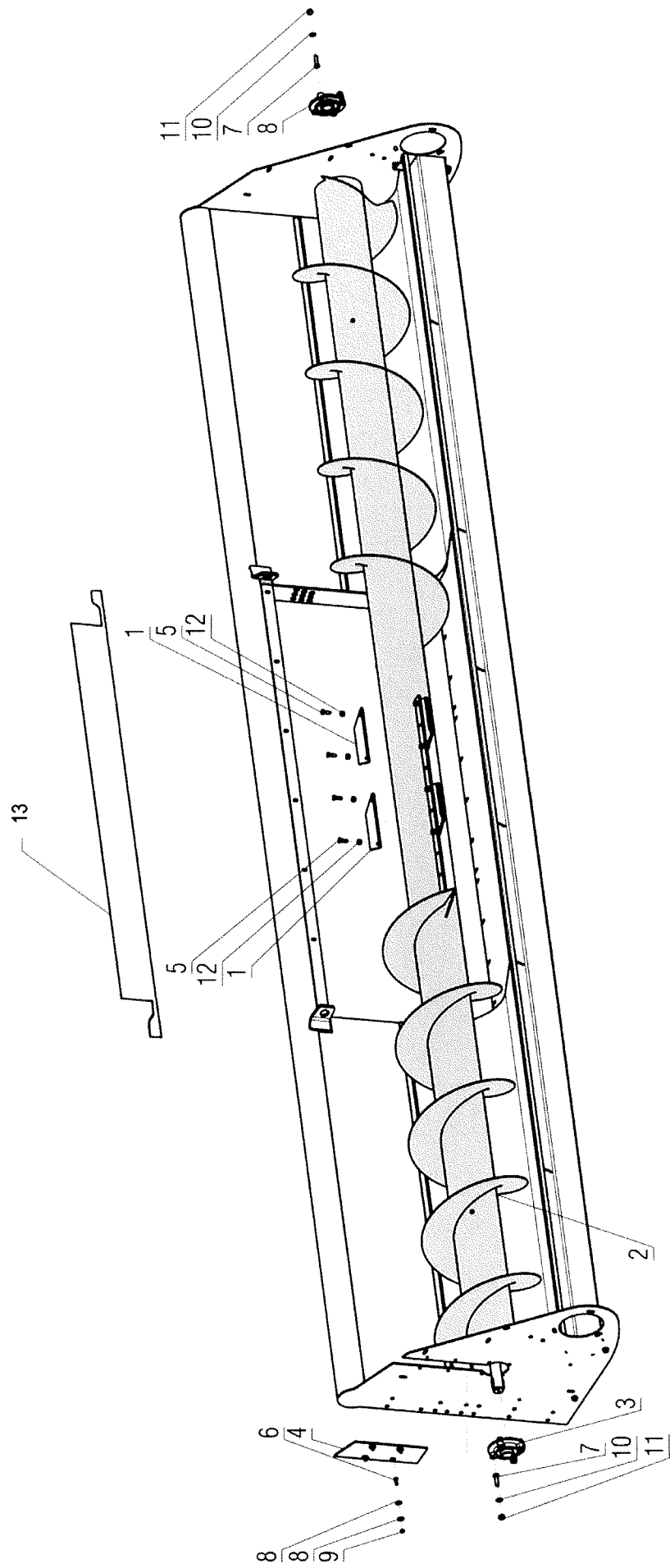
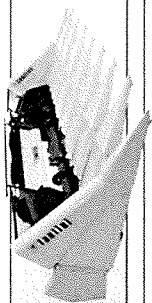

P.	CODICE Code	Qt.	DENOMINAZIONE Description	PREZZO Price	P.	CODICE Code	Qt.	DENOMINAZIONE Description	PREZZO Price
1	12694	4							
2	01834	1	10X45 L =4630						
2	01836	1	10X50 L =5080						
2	10569	1	10X70 L =6880						
2	01838	1	12X45 L =5530						
2	22533	1	12X56 L =6740						
2	22570	1	2X70 L =1280						
2	17238	1	2X75 L =1183						
2	17504	1	2X90 L =1480						
2	19354	1	4X50 L =2080						
2	09445	1	4X55-60 L =2280						
2	01840	1	4X70 L =2680						
2	01842	1	4X75 L =2830						
2	01844	1	4X80 L =2980						
2	17701	1	4X90 L =3280						
2	01846	1	5X70 L =3380						
2	20692	1	5X70 L =3380						
2	01848	1	5x75 L =3580						
2	01850	1	5X80 L =3780						
2	01852	1	6X50 L =3080						
2	01854	1	6X70 L =4080						
2	01857	1	6X75 L =4330						
2	21712	1	6X76 L =4380						
2	01860	1	6X80 L =4580						
2	17455	1	6X96 L =5405						
2	01862	1	7X45 L =3280						
2	01864	1	7X60-9X45 L =4180						
2	01866	1	7X75 L =5080						
2	01868	1	7X80 L =5380						
2	21280	1	8X1015 L =1028 DX						
2	21281	1	8X1015 L =1028 SX						
2	01876	1	8X15 L =5830						
2	01870	1	8X45 L =3730						
2	21713	1	8X55 L =4430						
2	01872	1	8X60 L =4780						
2	01874	1	8X70 L =5480						
2	19299	1	8X76 L =5900						
2	22290	1	8X91,5 L =6985						
2	17441	1	9X75 L =6580						
3	01410	2							
4	02945	1							
5	00384	8	TE M10X30 UNI 5739						
6	00377	4	TE M08X25 UNI 5739						
7	00450	8	TE M12X40 UNI 5737						
8	00946	4	M08 UNI 6592						
9	04858	4	M8 UNI 7473 AUTOB.						
10	00947	4	M12 UNI 6592						
11	04860	4	M12 UNI 7473 AUTOB						
12	00905	4	M12						
13	17417	1							

03

COCLEE 12 FILE G03
AUGER WITH CLUTCH 12 ROWS G03
VIS D'ALIMENTATION 12 ÉLÉMENTS G03



UP TO 2012

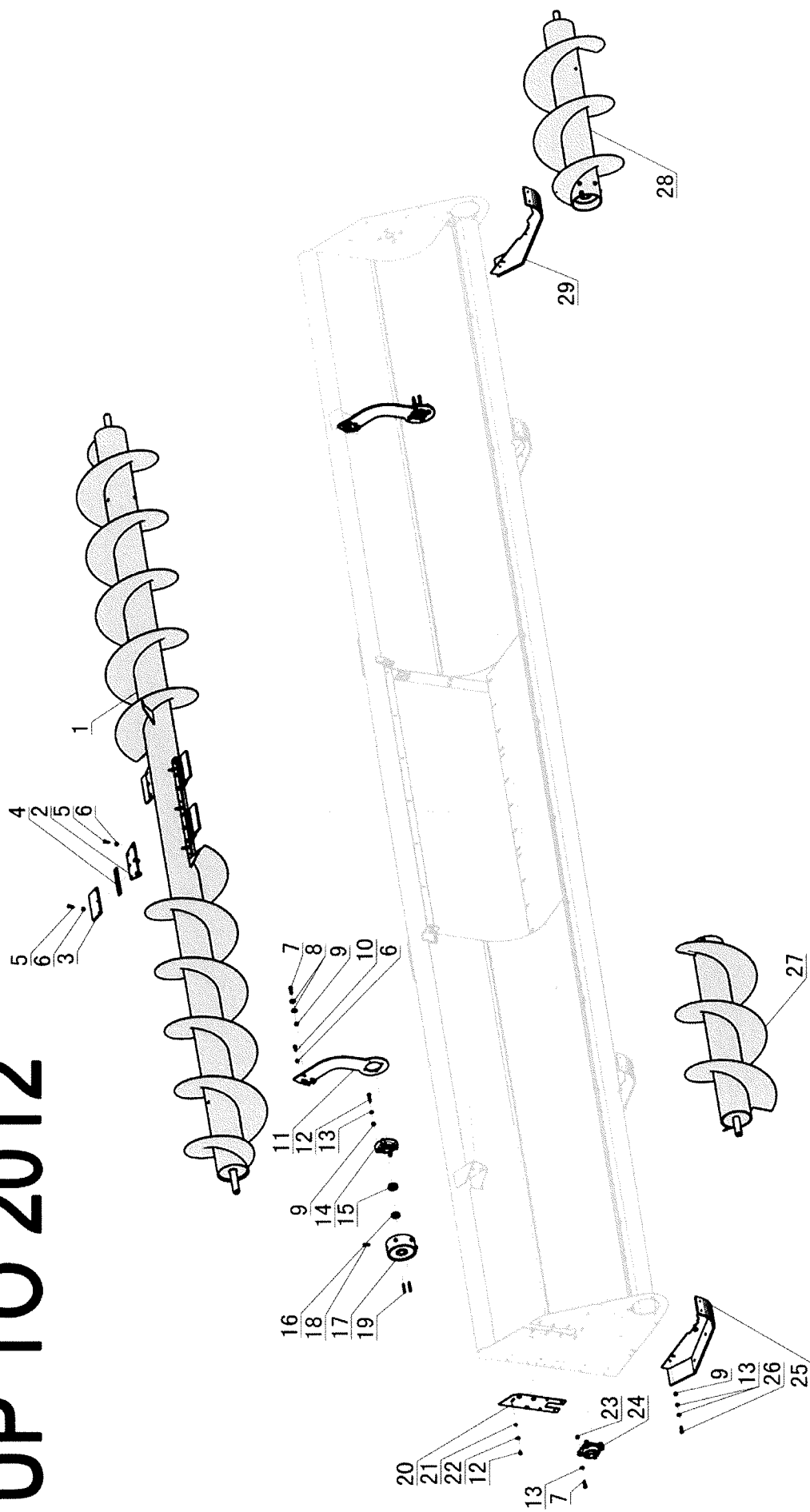

P.	CODICE Code	Qt.	DENOMINAZIONE Description	PREZZO Price	P.	CODICE Code	Qt.	DENOMINAZIONE Description	PREZZO Price
1	16012	1	C 12FILE						
2	21980	4	L=256						
3	21941	4	L=192						
4	21979	4	L=196						
5	00403	8	TE M10X35 UNI 5739						
6	04859	22	M10 UNI 7473 AUT						
7	00450	14	TE M12X40 UNI 5737						
8	09361	12	33X13X5						
9	04860	18	M10 UNI 7473 AUT						
10	00384	8	TE M10X30 UNI 5739						
11	17799	2							
12	00390	4	TE M12X50 UNI 5737						
13	00947	16	M12 UNI 6592						
14	13788	2							
15	21976	2							
16	09529	2	45X40-27						
17	19744	2							
18	00371	*	TE M12X30 UNI 5739						
19	21690	*	10X08X070 UNI 6604-69B70						
20	02945	1							
21	04858	4	M8 UNI 7473 AUT						
22	00946	4	M08 UNI 6592						
23	00479	*	M12 UNI 5587						
24	01410	2	SUPPORTO BLOCC GRA. D40						
25	21921	*							
26	00450	*	TE M12X40 UNI 5737						
27	16014	1	R 12X70						
27	22449	1	R 12X75						
27	19594	1	R 12X76						
28	16016	1	L 12X70						
28	22450	1	L 12X75						
28	19595	1	L 12X76						
29	21922	1							

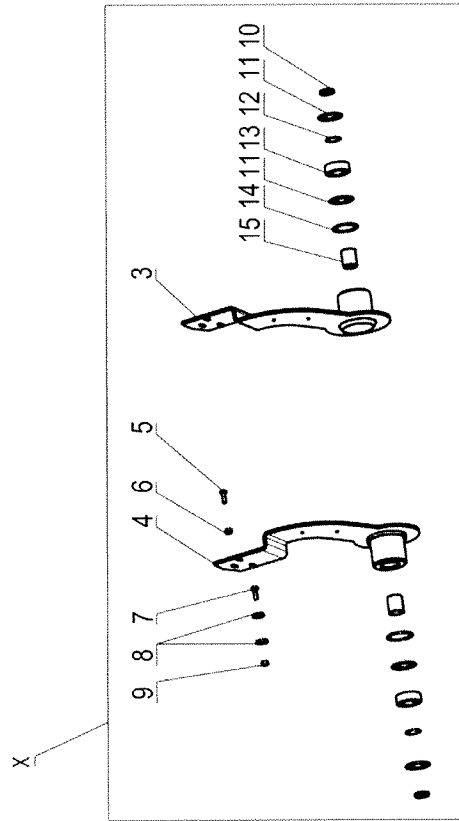
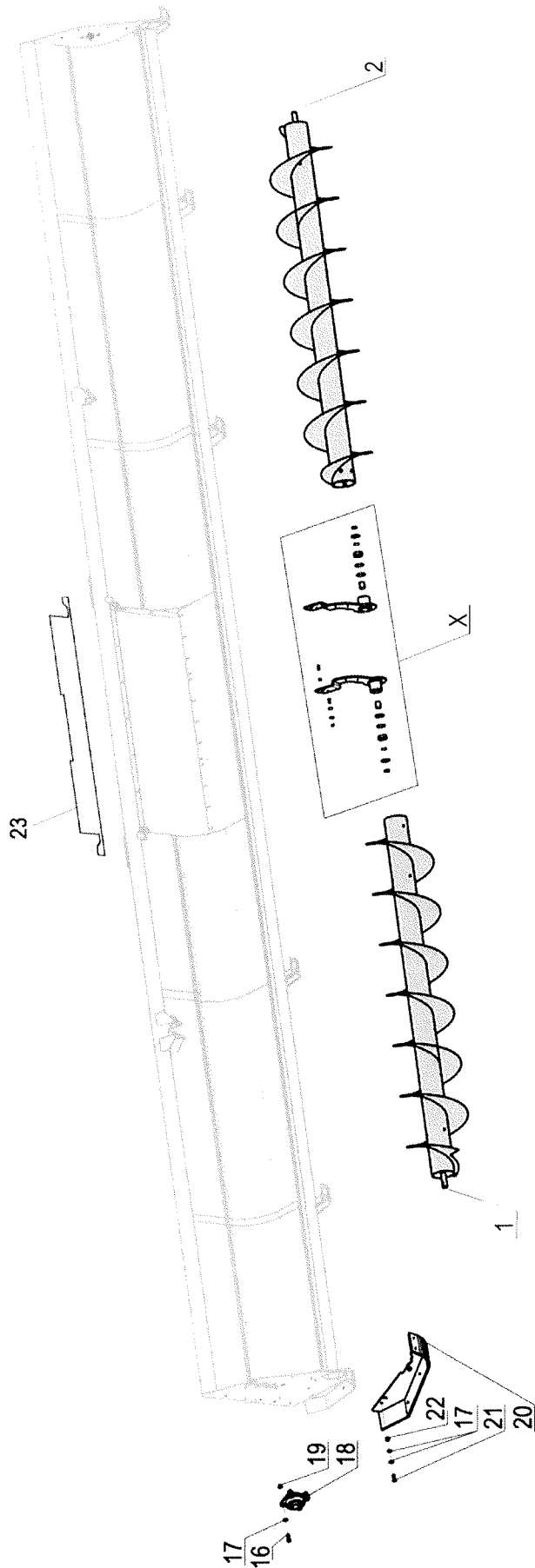

P.	CODICE Code	Qt.	DENOMINAZIONE Description	PREZZO Price	P.	CODICE Code	Qt.	DENOMINAZIONE Description	PREZZO Price
1	23042	1	R 12x70						
1	23043	1	R 12x75						
1	23040	1	R 12x76						
2	23041	1	L 12x70						
2	23044	1	L 12x75						
2	23039	1	L 12x76						
3	22288	1	L						
4	22287	1	R						
5	00384	2	TE M10X30 UNI5739						
6	04859	2	M10 UNI 7473						
7	00450	6	TE M12X40 UNI5737						
8	09361	12	33X13X5						
9	04860	6	M10 UNI 7473						
10	22235	2	42X35-6						
11	01330	4	NILOS 6207 JV						
12	01038	2	35X45X25						
13	01287	2	2207-2RS						
14	19479	2	INT. Ø 72 UNI7438						
15	23432	2	42X35-45						
16	00450	14	TE M12X40 UNI 5737						
17	00947	16	M12 UNI 6592						
18	01410	2	SUPPORTO BLOCC GRA. D40						
19	00479	*	M12 UNI 5587						
20	21921	*							
21	00450	*	TE M12X40 UNI 5737						
22	04860	18	M10 UNI 7473 AUT						
23	24012	1							

Q01

IMPIANTO IDRAULICO
HYDRAULIC SYSTEM
SYSTÈME HYDRAULIQUE

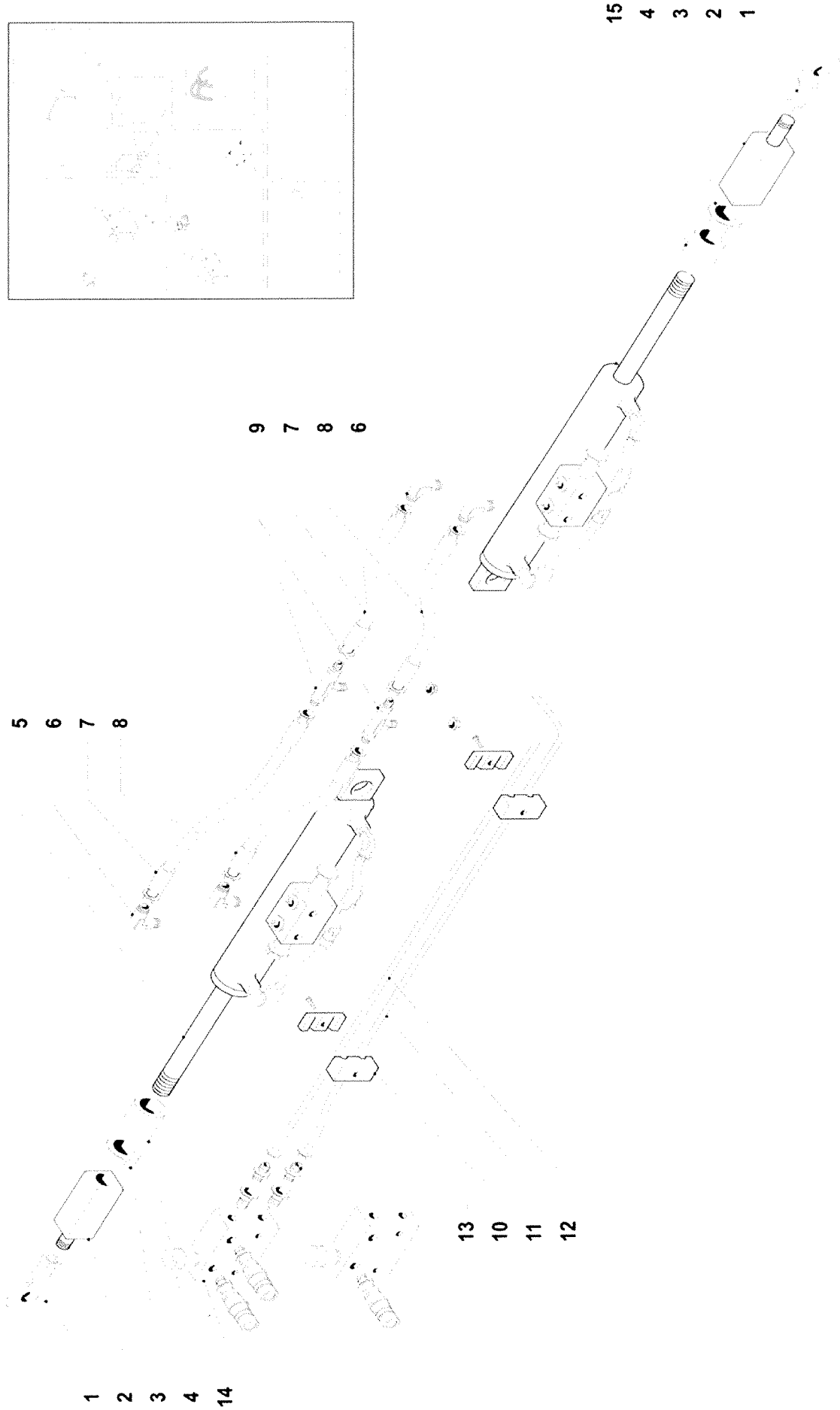

P.	CODICE Code	Qt.	DENOMINAZIONE Description	PREZZO Price	P.	CODICE Code	Qt.	DENOMINAZIONE Description	PREZZO Price
1	16602	2	GIL30DO-2RS M30X2	11					
2	09086	2							
3	08651	3	M30 UNI 5589 B						
4	21242	2	6 FILE						
4	21243	2	8 FILE						
5	21245	1	L 12 FILE						
5	08339	1	L 6 FILE						
5	09941	1	L 8/10 FILE						
6	09301	4	3/8G+T10						
7	11101	2	T10+F3/8						
8	11100	2	T10+F3/8						
9	01932	2	T10+T10+T10						
10	02927	2	T10+T10						
11	11131	1	Ø10 L=1125						
12	11132	1	Ø10 L=1100						
13	01925	2	1/4G+T10						
14	09231	1							
15	21244	1	R 12 FILE						
15	08336	1	R 6 FILE						
15	09940	1	R 8 FILE						

fantini
the best harvest since 1968